



# Lewes Home Retrofit Guide



DEEPER  
GREEN by design

Suzy Nelson and Ann Link are the principal authors of this guide. The drawings of buildings details are by Ian McKay of Deeper Green and the document is designed by Lynda Durrant of Full Circle Design



We would like to thank Frances Lord for help with editing the text and Nick Rouse of Ovesco for his comments on the section on microgeneration. Thanks to Nicki Myers of Ovesco, Rachel Paget of Adur and Ouse River Trust, Diana Collins, and Carol Smyth of Design.hindover for photographs.

Small grants from Lewes Town Council and Community Energy South have supported the production of the guide, but it has largely been produced by voluntary labour.

Whilst we have taken every effort to ensure that the information contained within the guide is correct, we cannot take responsibility for errors or omissions contained within it. You should take professional advice specifically for your project.

This work is licensed by Nevill 2030, Lewes Climate Hub and DeeperGreen under a Creative Commons Attribution Non-Commercial-NoDerivatives 4.0 International Licence. This licence enables reusers to copy and distribute the material in any medium or format in unadapted form only, for noncommercial purposes only, and only so long as attribution is given to the creator. CC BY-NC-ND includes the following elements:



-  BY: credit must be given to the creator.
-  NC: Only noncommercial uses of the work are permitted.
-  ND: No derivatives or adaptations of the work are permitted.

Published in September, 2024 by Nevill 2030, Lewes Climate Hub and DeeperGreen

This brochure has been funded by Community Energy South with support from the Ouse Valley Climate Action programme that is a Lottery Climate and Energy programme. Community Energy South is a social enterprise that supports capacity building for Communities looking to decarbonise their energy use.

Supported by



# Contents

4	Introduction	33	Heat pumps
5	The range of homes in Lewes District	36	Micro generation
6	A fabric first whole house approach	40	Sustainable drainage
8	Heat losses	42	Planning
8	Heat gain	44	Building Control
9	Insulation	45	Grants
12	Draught proofing	46	Loans
13	Ventilation	46	Low cost options
16	Insulating roofs	46	VAT and energy-saving materials and heating equipment
20	Wall insulation	47	Advice with paying bills
25	Windows and doors	48	Useful resources
28	Insulating floors		

# Introduction

This guide aims to provide householders with advice on how to make their homes more energy efficient, comfortable, and cheaper to heat. It sets out the principles which underpin best practice in retrofit, and explains how to limit draughts, install insulation to different building elements, control ventilation and minimise the risk of condensation. It also includes information about heat pumps, solar panels, and sustainable drainage.

There are different ways you might approach saving energy in an existing house, which can include turning down the thermostat or having showers instead of baths. But this guide concentrates on retrofit, with a fabric first approach: addressing how the materials of the house can be changed or added to, so that the house needs less energy to run. Our vision is for every home in Lewes to be affordable to run, comfortable and healthy to live in, as well as helping to achieve Lewes District Council's goal of net zero carbon emissions.

**The guide will help householders to develop strategies for improving the energy efficiency of their homes and to be able to have informed conversations with building professionals. It is not intended as a substitute for getting professional advice about retrofitting your home, or as a guide to carrying out the work yourself.**

During lockdown a group of us living on the Nevill, a neighbourhood on the edge of Lewes, formed Nevill 2030 to discuss how we could address the challenges of the climate emergency. One idea which emerged was producing a guide for householders on how to improve

the energy efficiency and comfort of our homes, and reduce running costs. Funding from Lewes Town Council enabled us to subsidise a number of whole house retrofit plans. These were useful in identifying strategies for improving energy efficiency, but the diversity of houses, with extensions and alterations, led us to change the structure of the guide. We had intended to centre it on a series of common house types but experience with the retrofit plans led us to decide to make it about a set of house “elements” such as roofs, walls and sloping ceilings.

Following feedback from Lewes Climate Hub's 'Warm Your Home!' exhibition and talks season in November 2023, we decided to focus the guide on Lewes as a whole. Ian McKay, a local architect and founder of Deeper Green, prepared excellent panels for the exhibition, which have been used as the basis for the illustrations in this guide.





## The range of homes in Lewes District

Whilst most of the homes in the historic core of Lewes Town were built before the First World War, and are in the conservation area, the majority of homes in the town are in areas such as Nevill, Landport, Malling and Winterbourne, which were developed after the First World War. Elsewhere in the district there is a mix of homes built in different periods, but as in Lewes Town most were built after 1918. If your home is listed as being of historic value or is in a conservation area, it can be more challenging to make changes. Homeowners may have to apply for additional permission to carry out improvement works as well as meeting other planning requirements. Nonetheless, the whole house approach advocated in this guide together with advice on improving the insulation of building elements, controlling ventilation and avoiding the risk of condensation is relevant to all homes in the district.

The majority of homes in Lewes District are houses rather than flats. Retrofitting flats is likely to present some additional challenges. If flats are owner occupied, some works may require the permission of the landlord or need to be done in collaboration with the other leaseholders.

All homes, whether they are owner occupied or tenanted, need to be energy efficient. Whilst the majority of homes in Lewes District are owner occupied, 11% are for social rent and 17% are privately rented (East Sussex Joint Strategic Needs Assessment, 2021). Owner occupiers, if they can access the necessary finance, can initiate their own improvements. In tenanted properties landlords are responsible for meeting Minimum Energy Efficiency Performance 'E'. However, this is a very low standard and unfortunately the last Government scrapped proposals to raise the energy efficiency standard for rented homes. Some government funding for energy improvements can be accessed directly by tenants on low incomes (see section on funding in this guide). Tenants may wish to undertake some low-cost improvements themselves, such as draught-proofing. Lewes District Council has obtained funding from the Government's Social Housing Decarbonisation Fund to improve the energy efficiency of council homes and is implementing a programme of retrofit works.

# A fabric first whole house approach

The guide advocates a fabric first whole house approach to retrofit. This means developing a holistic strategy which addresses the materials and construction of the house, and which will help avoid problems of poor thermal performance and condensation. In 2019, the government introduced new rules for retrofitting dwellings, called PAS 2035. This was because of problems that had arisen with poor quality retrofit. It sets standards for how domestic retrofits are carried out and encourages a fabric first whole house approach, as the most technically sound way to undertake retrofit projects. This means maximising the performance of the building fabric before introducing new mechanical or electrical services. The aim of this approach is to minimise the amount of energy needed to keep our homes comfortable. Whilst compliance with PAS 2035 is a requirement only for publicly funded projects, it provides useful insights on how to manage any retrofit project. It covers the assessment of dwellings for retrofit, identification and evaluation of options, and monitoring the implementation of retrofit works. It also stresses that before undertaking energy saving improvements, one must ensure that the building is in good repair.

Piecemeal retrofits may have unintended consequences, so it is important that improvements are planned and work together effectively. A whole house plan, produced by a retrofit assessor, will propose a number of improvement options and model their impact on energy efficiency. The assessor will establish the occupiers' priorities and preferences, and carry out a detailed survey of the existing building. It may not be possible to carry out all the proposed work

at once, so the plan can propose a schedule for undertaking the work in phases. It may also be advantageous to split the work into phases to benefit from reduced rates for VAT on some energy saving improvements.

Retrofit assessments use computer based energy simulation models to evaluate the existing energy performance of homes and to evaluate the effect of proposed improvement measures. All models are a compromise between ease and speed of use, and detail (and thus accuracy). Government funding is generally linked to EPC ratings of homes, which use the reduced data Standard Assessment Procedure for modelling energy performance. The German Passive House Institute, famous for its low energy building assessment process, have now brought out the EnerPHit standard for low carbon refurbishment projects. It requires extensive energy modelling towards its very exacting certification criteria. It is compulsory to use the PassivHaus Planning Package software for projects which aim for certification as meeting the EnerPHit standard. Retrofits which achieve this standard require very little energy to heat.

Each household will have to make decisions about how to balance upfront capital costs against future savings on running costs, and decide the priority that they want to give to reductions in carbon emissions. The extent of disruption resulting from retrofit works will also be an issue to consider. If you are planning major repairs or an extension, this will be a good time to think holistically about improving the energy efficiency of the whole building. Because there is limited

grant funding currently available in the UK, many households will opt to undertake work in phases.

Also, partly because of this limitation in grants, there is a debate about whether to prioritise deep retrofits, which maximise the reduction in energy needed to keep homes warm, or whether to opt for undertaking the most cost effective fabric improvements and installing photovoltaic panels and heat pumps now, and plan for further upgrading of the building fabric at a future date.

Retrofitting needs to be planned carefully to maximise the benefits and avoid pitfalls. Our homes need to have a continuous insulated and draught-proofed outer envelope, but still have enough ventilation. Gaps in insulation, which will result in cold spots where condensation can arise, need to be avoided. Thus, careful consideration needs to be given to the junctions between materials, edges and corners to ensure continuity of the insulation. Holes in the envelope, causing draughts, need to be avoided. Risks of condensation resulting from changes to building fabric and increased airtightness also need to be considered. With a reduction in unplanned draughts, ventilation needs to be designed to avoid a harmful build-up of moist air, toxins and particulates, and to ensure a replacement supply of fresh air.

Whilst this guide advocates a whole house approach, it recognises that most households will carry out improvements in stages. It therefore focuses on how to improve the energy efficiency of building elements. However, it is important not to neglect the places where they join in order to avoid cold spots or draughts. Risks of condensation resulting from changes to building fabric and increased airtightness also need to be considered.

Despite the various barriers, there is enormous potential for our houses to reach or get close to net zero energy use, and thus to prepare ourselves for the future.

**Energy Performance Certificates (EPCs)** were introduced in 2007 and are required whenever a property is built, sold or rented. An EPC contains information about a property's energy use and typical costs, and includes recommendations about how to reduce energy use. EPCs give properties ratings from A (most efficient) to G (least efficient).

EPCs need to be carried out by an accredited assessor. In the UK, the Standard Assessment Procedure (SAP) is used to assess the compliance of new homes with the Building Regulations. EPCs for existing homes are prepared using a simplified version of SAP. The reduced data SAP (rdSAP) involves using a range of assumptions for the thermal transmittance and air filtration to calculate energy performance, and this often results in discrepancies between the predicted and actual energy use.

In addition to providing information to householders, EPCs have become used as a tool in setting policy on energy efficiency, but they are poorly suited for this role as they do not incentivise improvements to the building fabric or encourage low carbon heating such as heat pumps. Many organisations, including the Committee on Climate Change, Building Research Establishment and Historic England, are advocating reform of EPCs.

# Heat losses

The proportion of heat lost through different elements will vary according to whether a dwelling is detached, semi-detached or in a terrace, and the shape of the external envelope of the building. The diagram below provides an indication of the proportion of heat loss through different building elements in an uninsulated house.

## Home Action Plan



Source: Ovesco's home action plan for Barcombe

# Heat gain

As our climate changes and summers become hotter, we need to think about keeping our homes cool in summer as well as warm in winter. Buildings can gain heat from outside by conduction through the building envelope, by convection with warm air coming into the building and by solar radiation through windows.

## Overhang and deciduous tree provide shade from summer sun whilst winter sun is able to penetrate into room

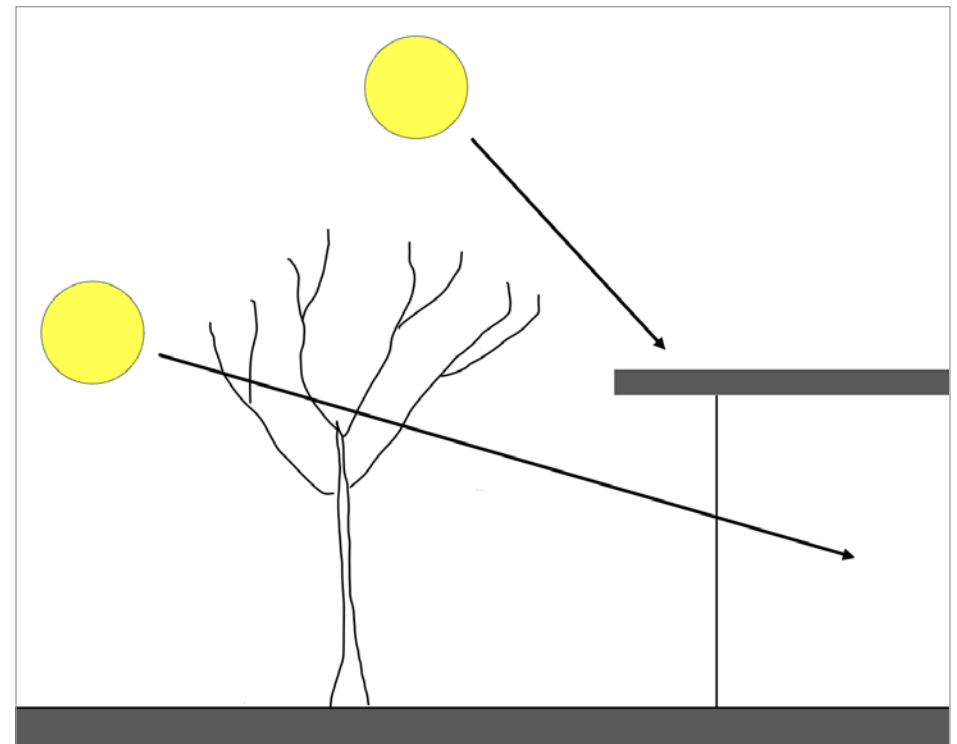

## Insulation

Solar radiation mainly consists of short-wave infrared radiation which can pass through glazing and heat up the internal fabric of a building. The long-wave radiation emitted back from the internal building fabric cannot pass through the glazing. Thus, heat accumulates in the interior of the building. This process is called the 'greenhouse effect'. Whilst solar gain can be beneficial in winter months, it can be problematic in summer months.

Improved insulation and controlled ventilation can help to manage problems of excessive heat gain in summer months. Solar gain can be managed by careful consideration of the amount and type of glazing and orientation of windows, and by shading. Windows can be shaded internally by blinds, but external shading may be preferable, because it can reduce the amount of heat gained by the building fabric. Windows can be shaded externally by roller blinds or shutters, overhanging roofs, awnings or projections above windows (known as brise soleil). Overhangs prevent solar radiation penetrating into the interior when the sun is high in the sky in summer, but allow it to penetrate in winter when the sun is lower in the sky. Deciduous trees, if positioned carefully, can also provide shading in summer, and let in solar radiation in winter.

Reducing heat loss through the building fabric by improving the insulation is crucial to improving the energy efficiency of our homes. When choosing insulating materials, thermal conductivity is a key property to consider. Other issues are vapour permeability and hygroscopicity.

The **thermal conductivity** of a material is a measure of its ability to conduct heat. It is measured in W/mK (Watts per metre per degree Kelvin). It is unrelated to the thickness of the material whilst the thermal transmittance (U value) varies according to the thickness of the material. **Thermal transmittance** is the rate of heat transfer through a material or a building element. It is referred to as the **U-value**. It is measured in W/m<sup>2</sup>K; this is the rate of flow of heat energy (in Watts) through one square metre of a structure when there is a temperature difference on either side of the structure of 1 degree (K or °C). The lower the U-value of building elements the more effective they are at resisting the flow of heat.

**Vapour permeability** is a material's ability to allow water vapour to pass through it. This can be a useful property as it can allow excess moisture to escape. It is sometimes referred to as breathability.

**Hygroscopicity** is a material's ability to absorb moisture from the surrounding environment. A hygroscopic material can absorb and store moisture from the surrounding air when humidity rises, and release it when humidity falls, thus reducing the risk of condensation.

A wide range of insulating materials can be used in retrofit. Natural materials include cork, wood fibre and hemp. Fossil fuel derived materials include expanded polystyrene and polyurethane foam. Most insulation materials work by trapping air or other gases within their structure; gases are good insulators because the molecules are relatively well spaced making heat transfer difficult. Metal based foils can be used to reflect heat. Natural materials such as wood fibre, hemp and sheep's wool are low in embodied carbon (carbon emissions related to the production and use of construction materials) and are vapour permeable and hygroscopic.

Vapour permeable materials reduce the risk of condensation being trapped within the building fabric. Hygroscopic materials also reduce the risk of condensation by acting as a buffer absorbing water vapour when vapour pressure is high and later releasing it. Natural materials generally have a lower environmental impact and emit less carbon in their production.

### Thermal conductivity of common insulation materials

	<b>Thermal conductivity W/mK</b>	
<b>Natural materials</b>		
Wood fibre	0.038	vapour permeable
Sheep's wool	0.038	vapour permeable
Cork	0.045	vapour permeable
Hempcrete	0.06-0.07	vapour permeable
<b>Mineral derived</b>		
Rockwool	0.032-0.044	vapour permeable
<b>Fossil fuel derived</b>		
PUR (polyurethane foam)	0.023-0.026	vapour tight
XPS (extruded polystyrene)	0.033	vapour tight
EPS (expanded polystyrene)	0.034-0.038	vapour tight

Careful consideration needs to be given to places where different materials meet, to ensure the continuity of insulation, avoid cold spots and reduce the risk of condensation.

## Highlighting continuity of insulation (shown in yellow)

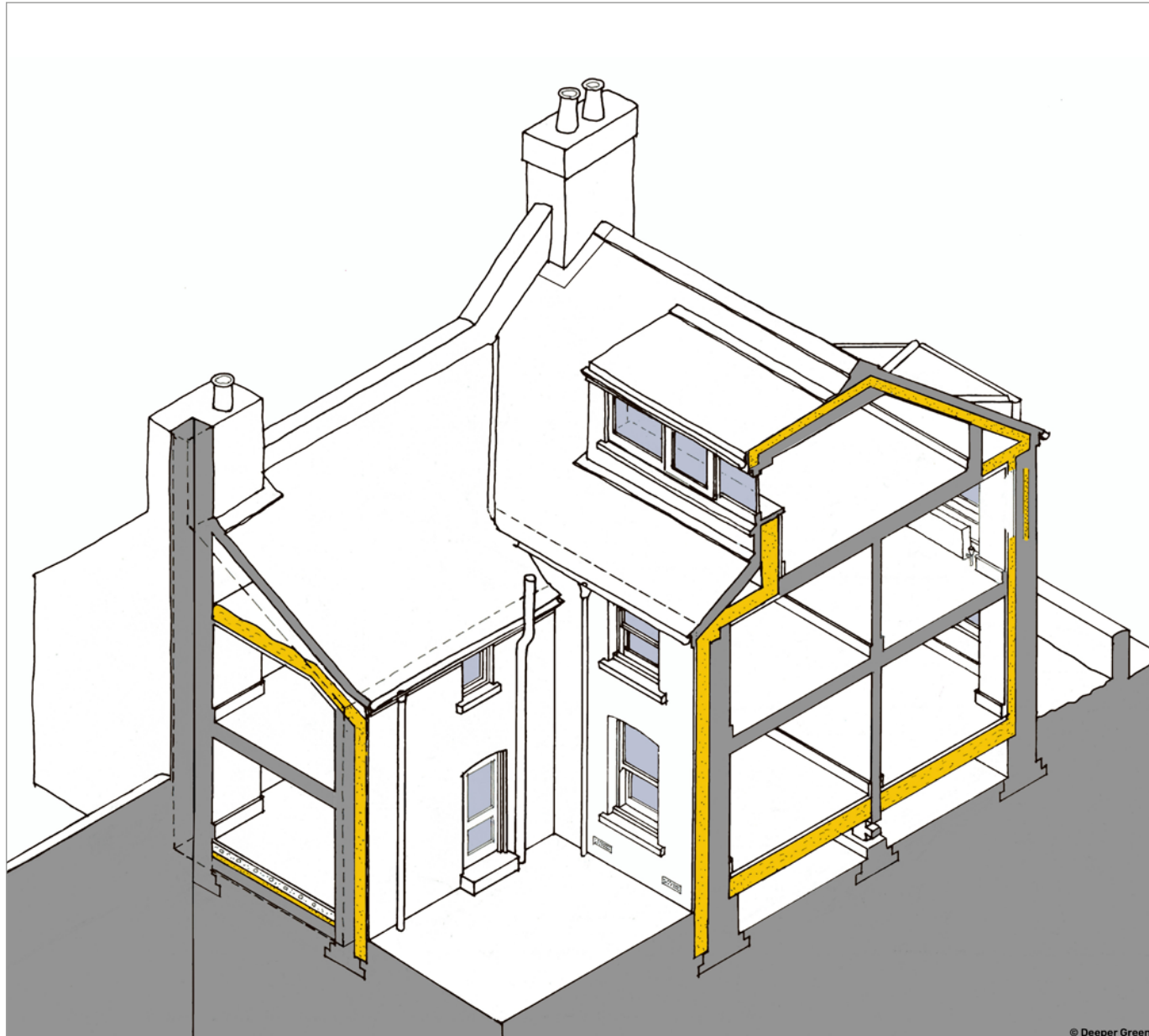

**Thermal bridges**, often referred to as cold bridges, have a higher thermal conductivity than the surrounding materials and thus a higher rate of heat loss. Because thermal bridges result in cold spots, they can be a focus for condensation on the surface or within the building fabric. Examples of thermal bridges are gaps between loft and wall insulation, and around pipework penetrating external walls.

## Draught proofing

With improved insulation, heat losses resulting from draughts account for an increasing proportion of the overall heat loss, and draught proofing will have a significant impact on reducing the cost of heating. As well as reducing heat loss and fuel bills, improving the airtightness of buildings will increase comfort. However, whilst it is important to reduce uncontrolled ventilation, it is essential to provide controlled ventilation to avoid the risk of condensation and ensure good air quality.

Simple draught proofing measures can be some of the cheapest and most cost effective ways to save energy. Unwanted gaps and holes which let cold air in and warm air out should be blocked. The Energy Saving Trust provides [advice about DIY draught proofing measures](#) for gaps around windows, doors, chimneys, floors, skirtings and pipework. Our local community energy organisation, Ovesco, has also produced an [advice leaflet on draught proofing](#).

When undertaking more major retrofit works, airtightness tapes can be used to avoid air leakage between different materials. To achieve a high standard of airtightness it is important to have a continuous air barrier.

**Draught proofing strip fixed to bottom of external door**



# Ventilation

With a reduction in unplanned draughts, ventilation needs to be designed to avoid a harmful build-up of moist air, toxins and particulates, and to ensure a supply of fresh air. Good ventilation is also crucial to reducing the risk of condensation.

Moisture is generated by respiration, bathing, cooking and drying clothes indoors. You cannot see water vapour. It is water in a gaseous form and is not to be confused with airborne water droplets like steam or fog. Without good ventilation to remove the excess water vapour, it can condense on cold surfaces promoting mould growth, which can aggravate respiratory illnesses such as asthma.

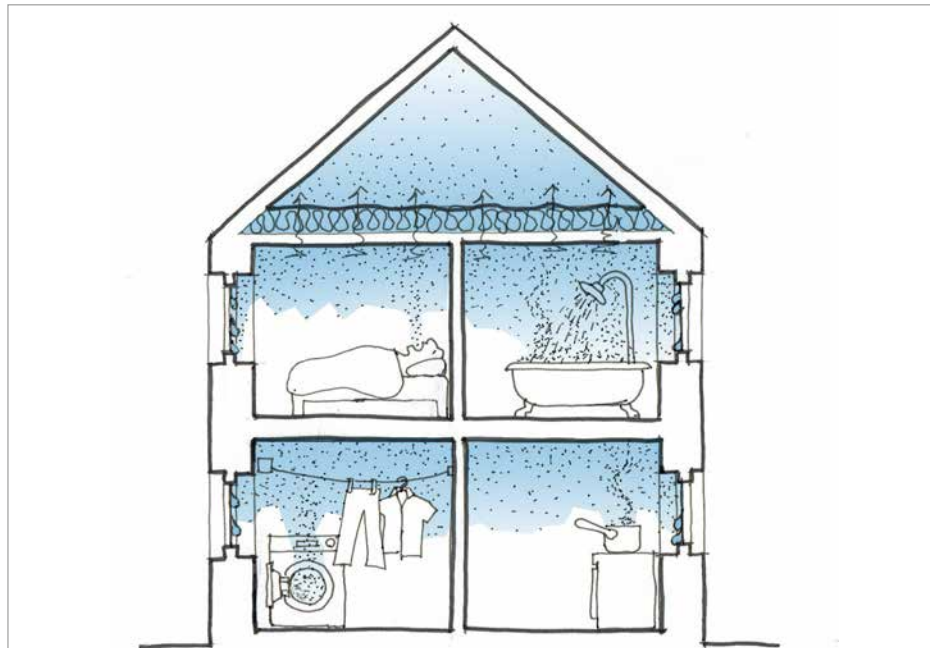

**Condensation** is the formation of water droplets when the temperature of warm moist air decreases. It can form on surfaces such as a window pane or uninsulated wall or within the building fabric, when it is called interstitial condensation. The resulting dampness can lead to mould growth, which can be harmful to health of the occupants, and can cause decay of structural elements such as floor joists. It is therefore important to assess the risks of condensation when retrofitting a building.

External air temperature: say 5°C

Internal air temperature: say 20°C

Internal wall face temperature: say 12°C

Dew point reached causing mould growth

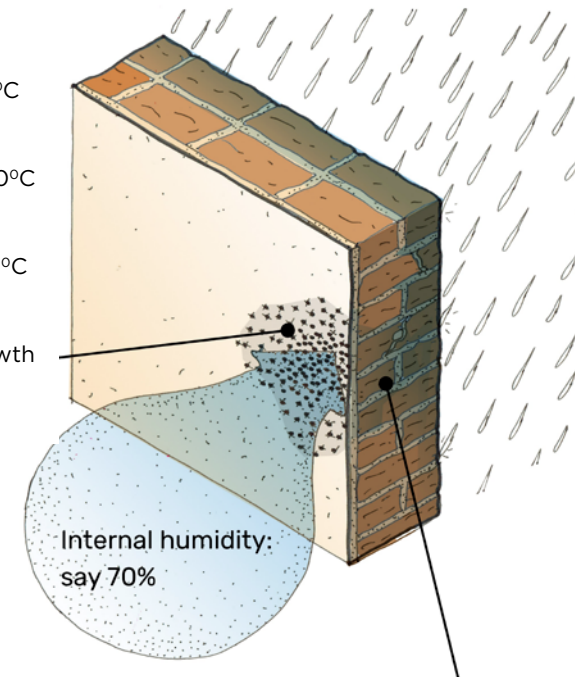

Saturated brick accelerates heat loss

## Intermittent mechanical extract ventilation

This is the ventilation system that is familiar to many of us. In the 1970s new Building Regulations were introduced requiring intermittent extract ventilation in wet rooms (kitchens and bathrooms) and fresh air inlets (usually trickle ventilation fitted in window frames) in living rooms and bedrooms. Gaps under doors are necessary to allow airflow within the dwelling. Such extract fans are usually activated by turning on the light switch, but they can also be activated when the relative humidity (the moisture level in the air at a given temperature) reaches a certain level. These fans can sometimes be be quite noisy, but some manufacturers now produce much quieter models.

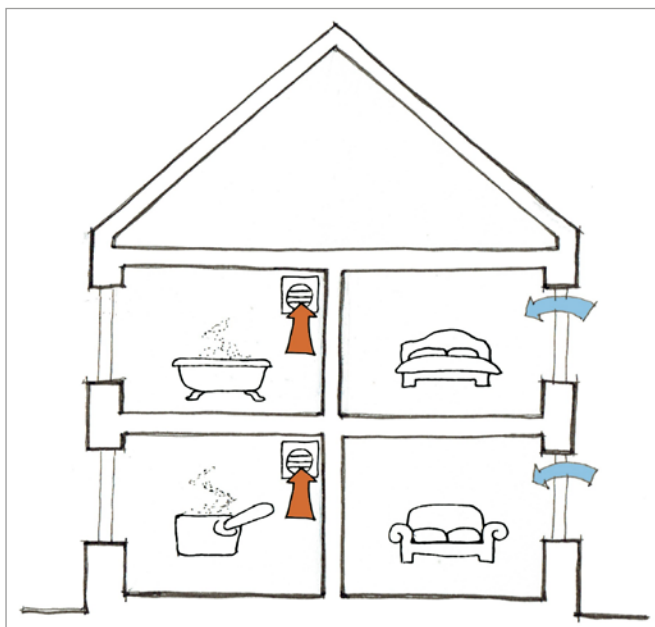

## Continuous mechanical extract ventilation

When increasing the standard of insulation and airtightness, you should consider installing more energy efficient systems of ventilation. Continuous mechanical extract ventilation extracts stale air from wet rooms at a background level and, when relative humidity rises, at a boosted level. When operating at a background level, these extract fans are nearly silent. Such systems can either be decentralised with separate fans in each wet room or with a single fan connected by ductwork to wet rooms. As with intermittent mechanical extract ventilation, living rooms and bedrooms need fresh air ventilation inlets (these may be trickle vents or wall inlets with humidity sensitive controls) and doors need to be undercut to allow air flow. In this system wet rooms should not have air ventilation inlets as fresh air intake should only be from living rooms and bedrooms.



## Mechanical ventilation with heat recovery

Retrofit projects designed to meet the Passivhaus EnerPHit standard require the installation of mechanical ventilation with heat recovery. Such systems continuously extract warm air from wet rooms and pass it over a heat exchanger and draw in a balancing supply of fresh air, which passes through the heat exchanger to warm the air. Such an installation will involve finding space to accommodate a box containing two fans and a heat exchanger and ductwork connecting all rooms, which can be difficult to accommodate in an existing dwelling.

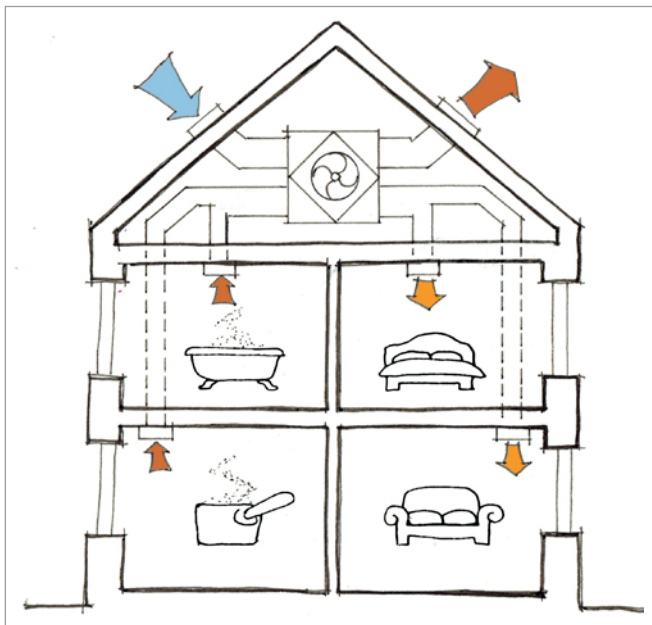

# Insulating roofs

Heat rises, so roof and ceiling insulation are the number one priorities for insulation and draught proofing. They are also generally the most cost effective.

## Loft insulation

Flat sections of the ceiling with loft spaces above can be insulated with one layer of insulation fitted snugly between the ceiling joists, and a second layer laid across the joists. However, many homes will have existing insulation, often 100mm between ceiling joists. If this is in good condition and well fitted, this layer can be retained and a second layer (usually at least another 200mm deep) can be laid at right angles to the lower layer. This cross layering helps to reduce the thermal bridging caused by the timber joists. Once the insulation is installed it is advisable to overlay a breather membrane, which will allow moisture vapour to pass through but provides resistance to airflow.

If the ceiling joists can take the load and the loft space is to be used for storage, a new floor should be installed above the insulation. This can be done by laying new joists at 90 degrees to the existing ones or by using proprietary 'loft stilts' to support the new flooring.

It is important to avoid gaps in the insulation and ensure the insulation continues to the walls, but does not block airflow into the loft space at the eaves, as ventilation is essential to prevent condensation.

Loft insulation (without replacing ceiling)

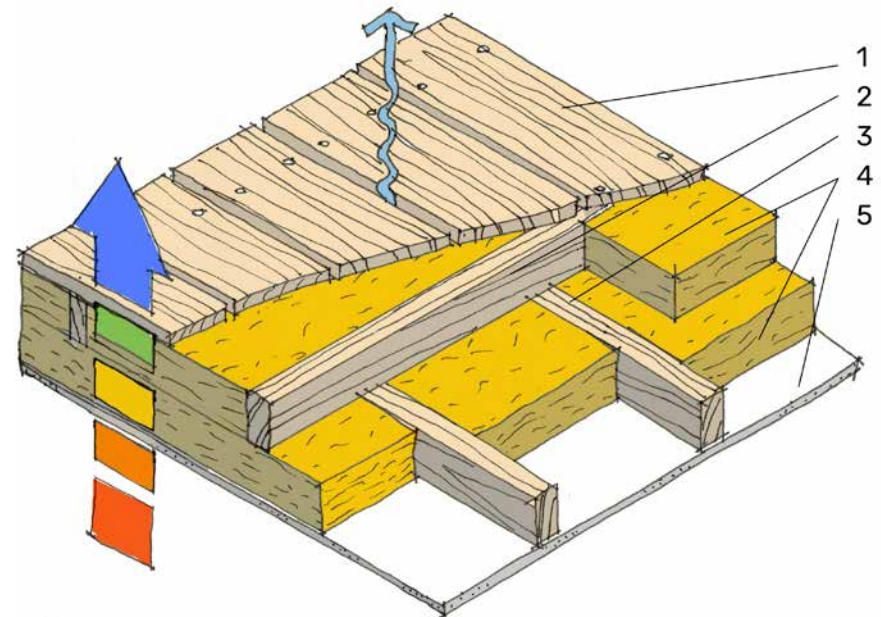

Key

- 1 new gapped floor boards (allowing water vapour to escape)
- 2 new counter joist fixed to the existing
- 3 existing ceiling joists
- 4 new between and above joist insulation
- 5 existing plasterboard or lath and plaster ceiling

### Eaves ventilation (before)

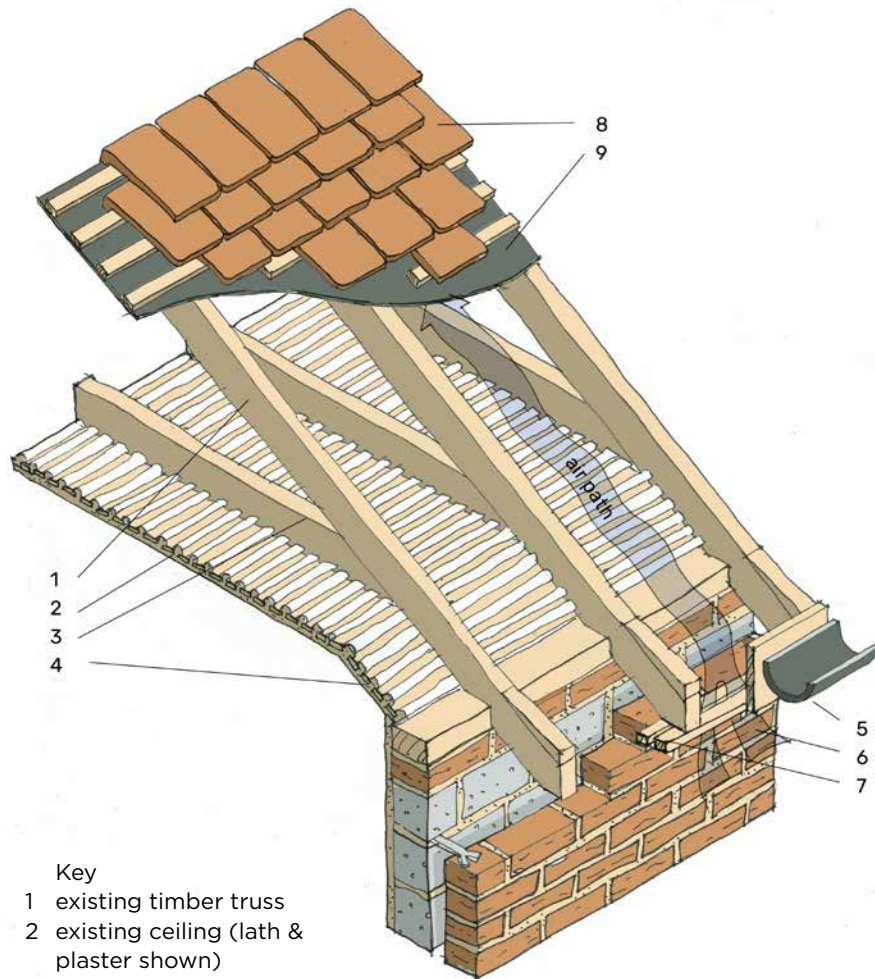

#### Key

- 1 existing timber truss
- 2 existing ceiling (lath & plaster shown)
- 3 existing ceiling joist
- 4 section of 'skeiling' (sloped ceiling)
- 5 existing gutter & fascia board
- 6 existing block and brick cavity wall
- 7 existing soffit ventilation
- 8 existing roof tiles/slates on tiling battens
- 9 existing sarking felt or sarking boards

Where services penetrate the ceiling, the joints should be sealed. Any redundant cables or pipes in the loft should be removed. Any water pipes in unheated loft spaces should be insulated. Alternatively, battens can be laid below ceiling joists to create a void to house pipes and cables.

Ceiling hatches are a potential weak spot. They can be insulated with rigid insulation (such as wood fibre board) and should have a draught seal fitted.

## Insulating skelings

Skelings or sloping sections of ceiling may be at the perimeter of a room or in a loft room. To achieve insulation to the standard of the current Building Regulations it will be necessary to remove existing ceiling plaster and fit semi-rigid insulation snugly between the rafters and an additional layer of insulation below. A path for airflow from the eaves to the loft space can be created by proprietary corrugated eaves ventilation trays or timber battens fitted along the side of rafters. Additional loft ventilation can be provided by installing roof tile vents and vents in gable walls.

In the case of small sections of sloping ceilings at the perimeter of a room, if one wants to avoid taking down the ceiling, the best option may be to insulate from below, but this will depend on the impact that the depth of the insulation has on the room below. It may also be possible to push semi-rigid insulation between the rafters, but it is essential to ensure a path for airflow to the eaves by maintaining a gap above the insulation. It would be advisable to use a hygroscopic material to protect the timbers from a build-up of moisture.

## Sk ceiling insulation with eaves ventilation

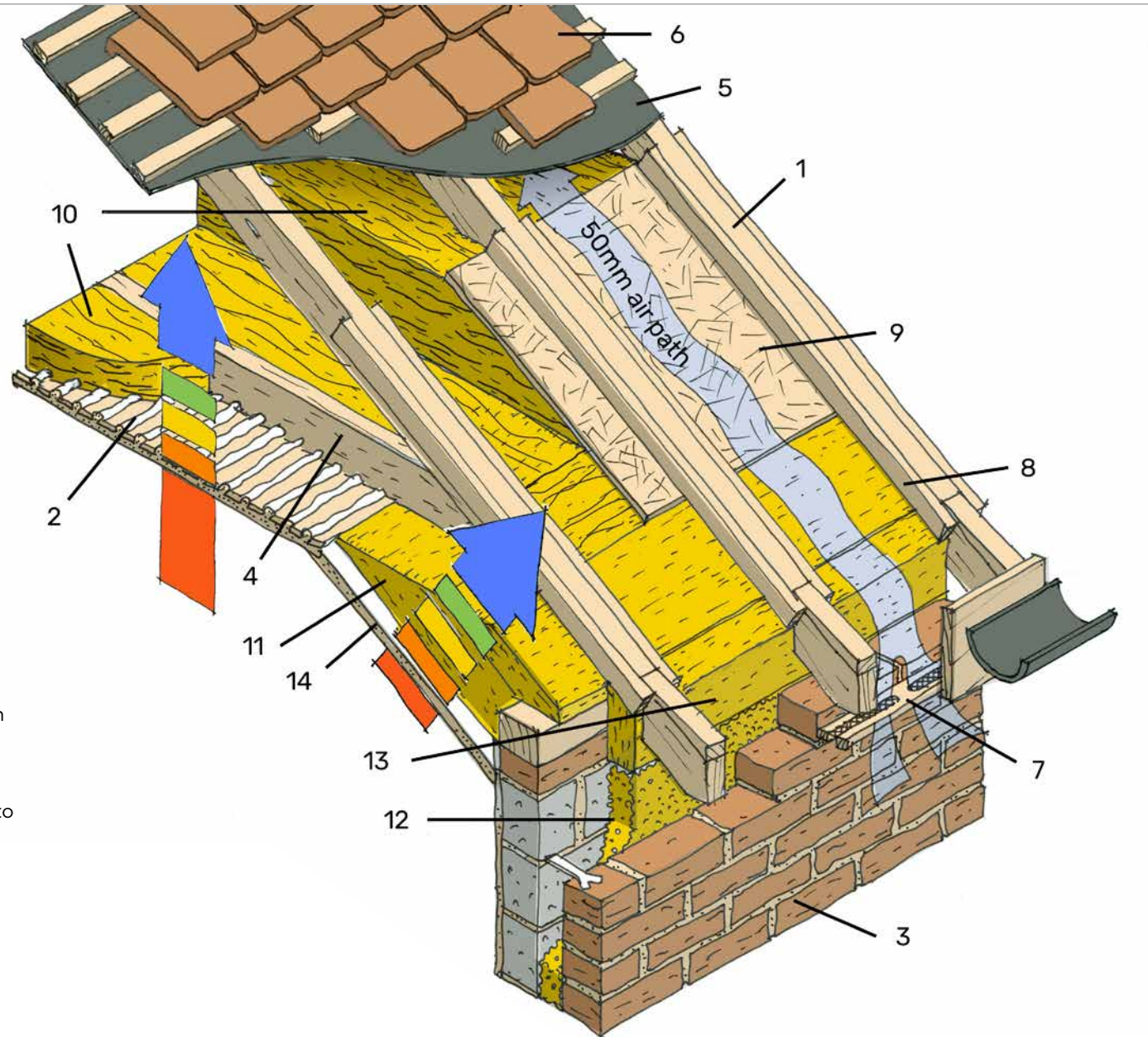

### Key

- 1 existing timber truss
- 2 existing ceiling (lath & plaster shown)
- 3 existing block and brick cavity wall
- 4 existing ceiling joist
- 5 existing or renewed sarking felt
- 6 existing roof tiles/slates on tiling battens
- 7 existing or renewed soffit ventilation with insect mesh
- 8 new 50mm deep timber battens fixed to the sides of the rafters
- 9 new ply or oriented strand board (OSB) to maintain 50mm air path above
- 10 new vapour open loft insulation quilt (typically 270mm + overall depth)
- 11 new vapour open sk ceiling insulation batt (ceiling line moved inwards)
- 12 new injected cavity bead insulation
- 13 new vapour open batt to infill cavity between rafters
- 14 new plasterboard

### Skelling insulation (after) detail

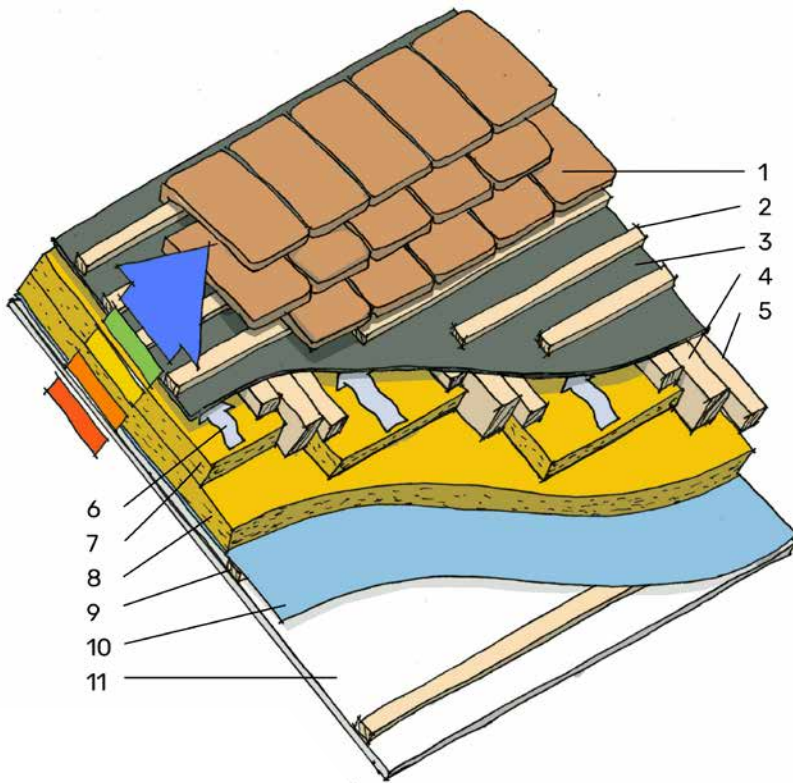

- Key
- 1 existing roof tiles
  - 2 existing timber roofing battens
  - 3 existing sarking felt
  - 4 existing timber rafter
  - 5 new softwood batten/spacers
  - 6 50mm ventilation zone from eaves to ridge
  - 7 new between rafter insulation
  - 8 new below rafter insulation
  - 9 new service zone batten
  - 10 new vapour control membrane or taped foil of insulation backing
  - 11 new plasterboard 'skelling'

## Insulating flat roofs

It is advisable to insulate flat roofs from above, to avoid the risk of interstitial condensation. This will involve removing the existing roof covering, ensuring that the roof decking is in good condition, then laying a vapour control membrane with rigid insulation above finished with a waterproof layer.

### Flat roof

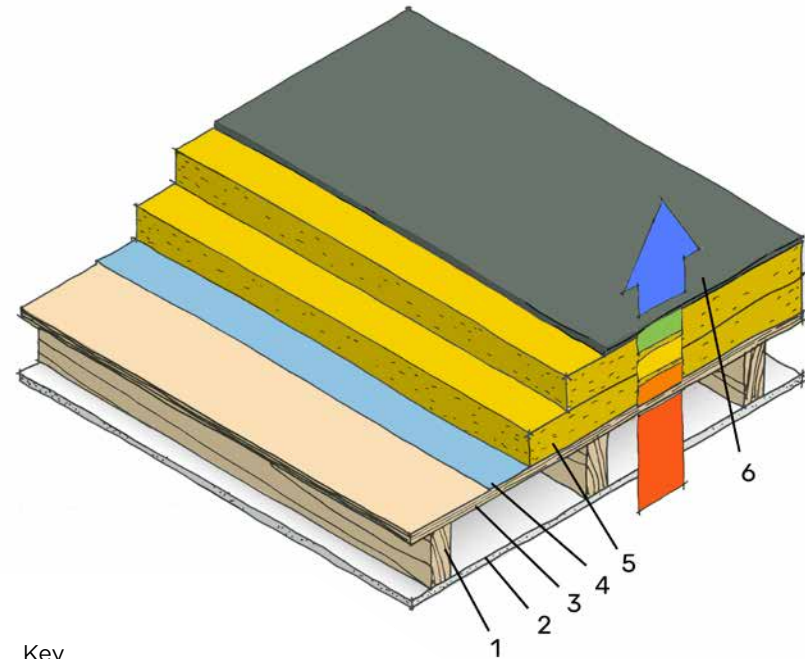

- Key
- 1 existing timber flat roof joists
  - 2 existing plasterboard ceiling
  - 3 existing or renewed plywood or OSB deck
  - 4 new vapour control membrane
  - 5 new 'warm roof' insulation (2 layers with staggered joints preferred)
  - 6 new weathering finish (ensure compatibility with substrate)

# Wall insulation

**Heat losses through walls account for the greatest proportion of heat losses from our homes, as walls make up the greatest proportion of the external envelope. Walls can be insulated externally, internally or in some cases within cavities. The relative merits of the different types of wall insulation need to be evaluated on a case by case basis.**

Cavity wall insulation can be the cheapest and simplest, but will not always be an option. External wall insulation will usually change the appearance of the building and is likely to require planning permission, but it has the advantage of providing a continuous layer of insulation and a lower risk of interstitial condensation than internal wall insulation. It also encloses the thermal mass of the masonry, which will moderate the internal temperature by absorbing and storing heat. Internal wall insulation may be a good choice if one wants to avoid changes to the external appearance of buildings. However, its installation will reduce the size of rooms and involve significant disruption, possibly requiring electrical fittings, radiators and pipework to be relocated. It will also be difficult to ensure continuity of the insulation where floors meet external walls. In some cases, the best solution may be to insulate the front walls of a house internally to avoid changing its appearance to the street, and insulate rear walls externally.

## Cavity wall insulation

Most of the external walls of houses built since the 1920s have cavities between an outer leaf of brickwork and an inner leaf of blockwork. The purpose of cavities is to stop rain penetration through the wall. Cavity wall insulation has been widely promoted, because it is relatively cheap and can effectively reduce heat loss, and the installation involves little disruption to the occupants. However, there are concerns that injection of cavity wall insulation can result in rain penetrating into the internal leaf of the wall, particularly in areas where walls are very exposed to driving rain. Unfortunately, a number of households in Lewes have experienced dampness following mineral wool insulation being inserted into their cavity walls and have had to have it removed. Using expanded polystyrene beads for filling cavities has a lower risk of damp penetration.

If you do decide to opt for cavity wall insulation, it is essential to remedy any defects in the external walls which would allow rain to penetrate into the cavity. This may involve repointing the external brickwork or renewing damaged external render. The installer of the insulation should carry out an inspection of the cavity to check that there is no debris and that the wall ties are in good condition. This is done by drilling a small hole in a mortar joint and inserting a digital inspection camera into the hole. You should ensure that your installation

is covered by a guarantee. The Cavity Insulation Guarantee Agency provides independent 25 year guarantees for cavity wall insulation fitted by registered installers.

Houses built since the 1980s will have been built with some insulation in the cavity due to changes in the Building Regulations. It has also become increasingly common for the inner leaf to be timber framed rather than masonry construction. Cavities of such walls are not suitable for the installation of further insulation.

### Cavity wall insulation

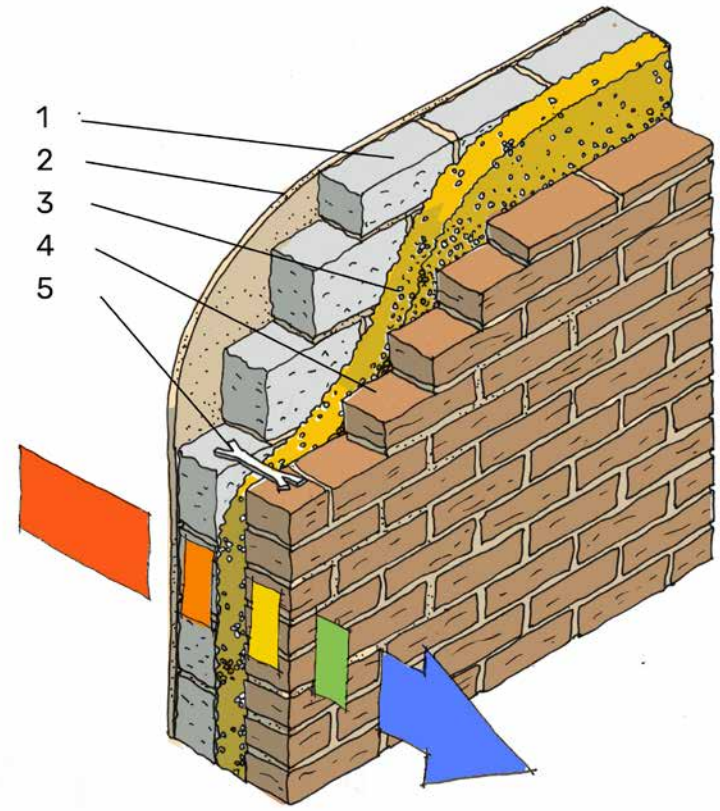

- Key
- 1 existing block or brick inner leaf
  - 2 existing internal plaster finish
  - 3 new injected cavity bead insulation
  - 4 existing brick (or block) outer leaf
  - 5 existing brick ties should be checked for integrity as part of the works

# External wall insulation

A variety of different insulation materials can be applied to external walls. Although external insulation presents less risk of condensation, it is still advisable to choose vapour permeable materials. The finish to external installation is generally render, which should also be vapour permeable. In some cases, brick slips are stuck on the render to give the appearance of brickwork.

It is important to ensure that the wall is in good condition prior to the installation of the insulation. Ideally any existing cement render and pointing should be removed and replaced with a thin coat of vapour permeable render to provide a smooth surface to which insulation can be fixed.

If external insulation is installed on walls with cavities, the cavity should be sealed or filled to prevent heat being lost through convection currents in the air in the cavity.

When installing external wall insulation there are various detailed design matters to consider. Rainwater pipes and soil pipes may have to be refixed on the outside of the insulation. Similarly, gutters and gutter boards may need to be relocated and this may involve extending the rafters, so that the roof extends over the external insulation. Roofing may also need to be extended to cover insulation on gable walls. Detailing around windows will need to be given careful consideration to avoid thermal bridges. If windows are to be replaced, ideally they should be fitted immediately behind the insulation. If existing windows are being kept, the reveals should be insulated. Insulation below the level of the damp proof course must be impermeable to water.

## External wall insulation

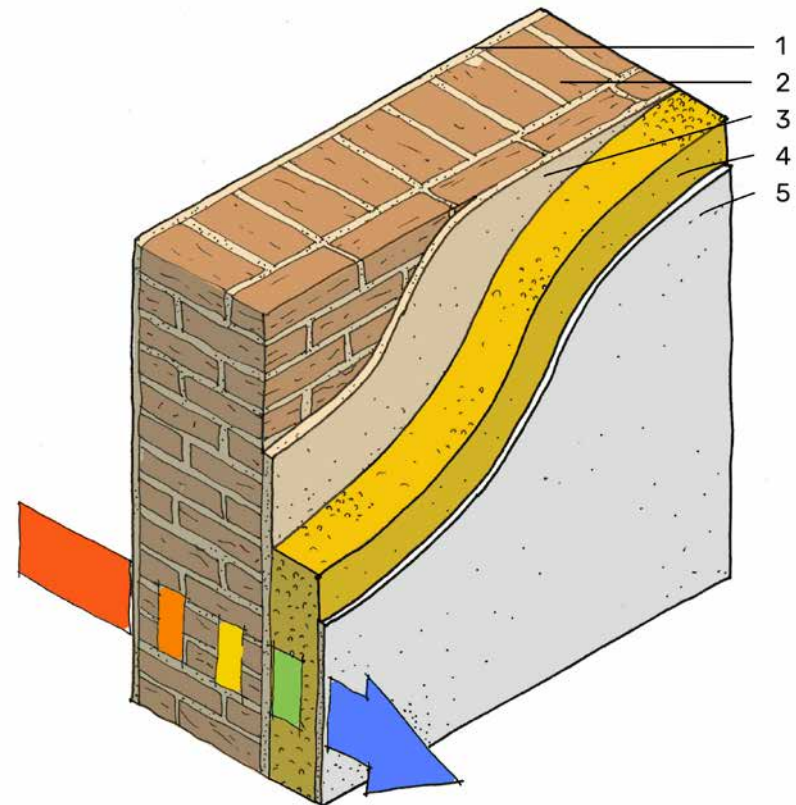

### Key

- 1 existing internal plaster finish
- 2 existing solid brick external wall
- 3 existing render finish or new 'parge' coat
- 4 new external wall insulation
- 5 new high performance mineral render

# Internal wall insulation

Internal wall insulation can be applied to either masonry walls or timber framed walls. As well as being used for the inner leaf of some modern cavity walls, timber framed construction was used in some historic buildings, some more recent bay windows and the walls of the front and rear elevations of some town houses built with masonry party walls.

Prior to installing internal wall insulation it is essential to check the condition of the wall and ensure that there is not a problem of either rain penetration or rising damp. Installing internal wall insulation can result in interstitial condensation within the building fabric, so the best approach is to use vapour permeable construction, which will allow moisture to escape. Ideally, existing gypsum plaster should be removed as although it is vapour permeable it crumbles when damp.

Again, careful consideration needs to be given to detailing to ensure continuity of the insulation. Wherever possible, the whole internal face of the wall should be insulated including between floor joists. Timbers such as joists built into masonry walls are at risk of being damaged by condensation. It is important to prevent this by avoiding cold spots. Services fixed to the inside of external walls will need to be refixed on the room side of the insulation or fixed to internal walls. To avoid a thermal bridge where the external wall meets the party wall, insulation should be extended along a short length of the party wall. Window reveals will need to be insulated.

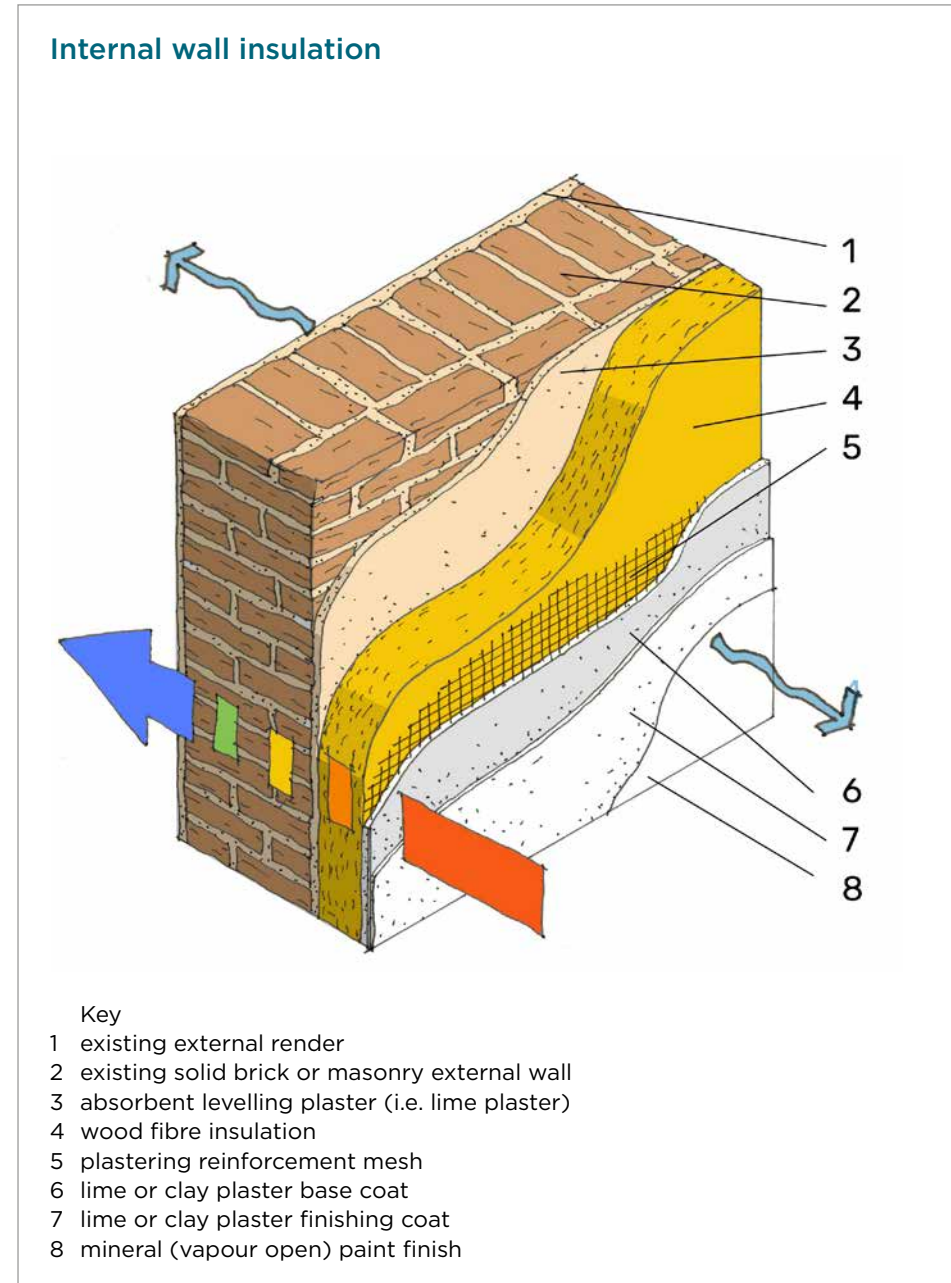

Timber framed walls may include some minimal existing insulation. Additional insulation can be inserted between and on the inside of the timber studs. A vapour control membrane should be installed on the warm side of the insulation to prevent water vapour entering into the interior of the wall. To avoid puncturing the vapour control layer you can install a 25mm extra layer (service zone) for pipes and cables, on the room side of the wall. See “after” diagram.

### Timber framed wall (before)

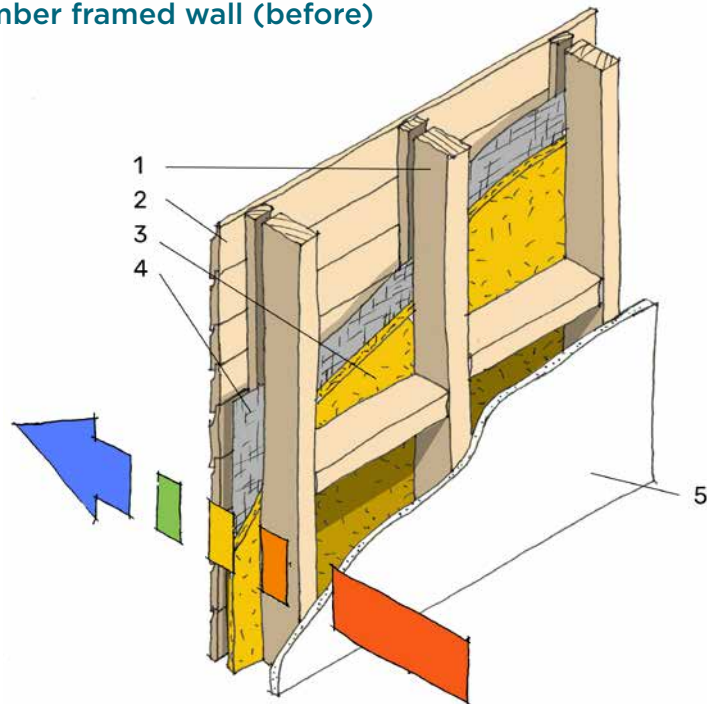

#### Key

- 1 existing timber studs and noggins
- 2 existing timber weather boarding on vertical timber battens
- 3 existing wood fibre insulation
- 4 existing building paper/sarking felt
- 5 existing plasterboard

### Timber framed wall with insulation (after)

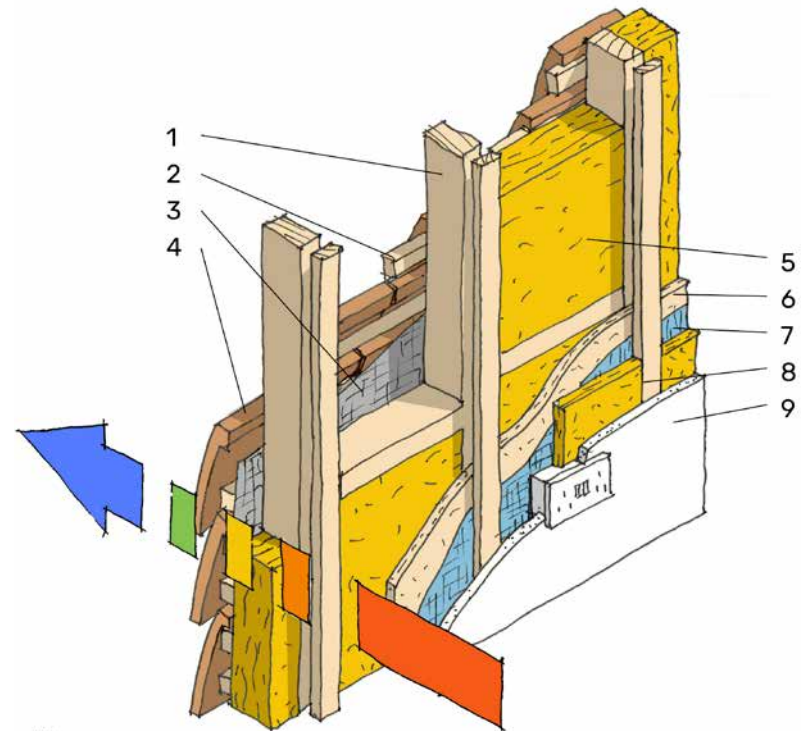

#### Key

- 1 existing timber studs and noggins
- 2 existing timber battens
- 3 existing building paper/sarking felt
- 4 existing clay hung tiles
- 5 new bio or mineral based friction fit insulation batt between studs
- 6 new oriented strand board (OSB) - possibly optional
- 7 new vapour control and air tightness membrane
- 8 new vertical battens to form service void infilled with insulation quilt
- 9 new plasterboard and skim

# Windows and doors

**Windows and doors are weak points in terms of thermal efficiency, as more heat is often lost by conduction through windows than through walls, and they are frequently the cause of draughts. Modern windows and doors offer much greater thermal efficiency and incorporate draught seals. The use of sealant tapes can prevent draughts coming through gaps between windows and adjacent walls.**

## Glazing

Double glazing can achieve a U-Value of 1.6 W/m<sup>2</sup>K, and triple glazing can achieve 0.8 W/m<sup>2</sup>K, compared to single glazing at around 4.8 W/m<sup>2</sup>.

Single glazing is so thermally inefficient that upgrading to double glazing has been one of the most cost-effective retrofit measures. As a result, many homes have already had double glazing installed and unless it is in poor condition, replacement with higher performance windows may be a priority only for those aiming for deep retrofits. If double glazing was installed some years ago, the seal between the panes may have become unstuck and the seals around opening windows may have deteriorated. Rather than replacing the window it may be an option to replace the glazing and seals. If you are installing new windows and doors, it is worth considering the relatively small additional cost of triple glazing. The British Fenestration Rating Council (BFRC) runs a scheme assessing energy efficiency of frame and glass with ratings from A++ to E.

As well as losing heat through glass, windows and doors lose heat through the frames. In double or triple glazed windows, generally the glass will have lower thermal conductivity than the frame and any mullions or rails. Hence, the higher the glass to frame ratio, the lower the U-value. It is therefore better to have fewer subdivisions within frames.

## Choice of material for new frames and doors

Timber framed windows and doors are a good option in terms of thermal efficiency and have a low environmental impact in terms of embodied carbon. If choosing timber, it is important to specify good quality windows and doors, which will be durable and easy to maintain. Timber windows made of laminated timber or thermally modified timber are more dimensionally stable and thus more durable. UPVC may be a cheaper option, but non-renewable resources are used and carbon dioxide is emitted in its production. Although aluminium is not a good insulant and involves a high level of embodied carbon in its manufacture, aluminium frames can incorporate thermal breaks, need little maintenance and can be recycled at the end of their life. Aluminium-clad timber windows have a thin shell of aluminium on a timber frame and are designed to maximise the benefit of both materials.

Traditional timber panelled doors provide poor thermal resistance, as although timber is a reasonably good insulator, timber panels are only a few millimetres thick. They do not comply with current building

## Well insulated external door



Source: Design.hindover

regulations, which require that the U-value of new doors should not exceed 1.4 W/m<sup>2</sup>K. Modern engineered wooden doors (made up of layers of timber with alternating grain) can provide the required standard of insulation and are more robust than traditional timber doors.

## Windows in Listed Buildings and Conservation Areas

In listed buildings, Conservation Officers will generally want single glazed historic timber windows to be retained if they are in good condition. If the glass is not of historic value, it may be possible to replace it with slim profile or vacuum double glazing in existing frames. Slim profile double glazing can have a thickness of as little as 12mm and vacuum glazing as little as 8.2mm. If historic windows are to be retained, Historic England offers advice about [draught proofing](#).

If windows are not of historic value or are in poor condition, heritage ranges of timber sash hung windows and simulated sash hung windows (with the upper sash fixed and the lower sash opening inwards) are now available. They may have mullions planted onto the glass to simulate multi-pane windows.

Further information on upgrading windows in heritage buildings and conservation areas is available in [Historic England's Guide to Traditional Windows](#) and the [Climate Emergency Conservation Area Toolkit](#).

## Secondary glazing

If replacing existing windows is not possible for heritage or budget reasons, secondary glazing is an option. Secondary glazing is an independent glazing system installed on the room side of existing windows. Heat loss can be reduced by as much as 60% by installing

secondary glazing with low emissivity coating facing the outside of the glass. Heat loss can be further reduced by installing secondary glazing which incorporates double or vacuum glazing. Care should be taken in the design of secondary glazing, so that it does not impact negatively on the external appearance of the building.

A DIY option is [magnetic strip secondary glazing](#), which is inexpensive and easy to install. It uses lightweight acrylic sheets, which can be taken down in the summer months.

### Trickle vents

While controlling draughts, it is important to maintain some ventilation to remove excess water vapour and supply fresh air. Building Regulations now require trickle vents, to ensure adequate ventilation. These are usually small holes or slots in door and window frames.

#### Trickle vent at head of window



Although they are designed to be left open, it is usually possible to manually close them. Whilst it may not be appropriate to incorporate trickle vents in the windows of listed buildings or in Conservation Areas, it is very important that the buildings are adequately ventilated. If you are installing mechanical ventilation with heat recovery, any existing trickle vents should be closed.

### Installation of new windows and doors

When installing new windows and doors, care needs to be taken to ensure the continuity of insulation and airtightness layers. It is advantageous to replace them at the same time as internal or external insulation, so that windows and insulation can be aligned to avoid thermal bridges and the need to insulate window reveals. Frames should be sealed to the adjacent building fabric with sealant tape to ensure airtightness.

### New window and door openings

When carrying out a major renovation or extension, it is important to consider the size and orientation of windows in terms of both heat loss and heat gain. Even triple glazed windows will lose heat at a faster rate than a thermally efficient wall, so it is important to carefully consider the overall amount of glazing to avoid excessive heat loss. Solar gain from south or west facing windows is welcome in winter months but can be a problem in summer months, so consideration should be given to their size and options for shading.

# Insulating floors

## Insulating timber ground floors

Insulating the ground floor will reduce heat loss and increase the comfort of the occupants. Before insulating a timber ground floor, it is important to assess its existing condition. Ground floors in older houses were generally built in timber. Floorboards are supported on timber joists, which span between timber wall plates supported on low walls (sleeper walls). The void below the floor is ventilated with air bricks in the external walls. It is essential that the underfloor space is adequately ventilated in order to reduce the risk of condensation which can cause timber decay. Air bricks must not be blocked and should provide a cross-flow of air. The gap between the floor timbers and the subfloor should be at least 150 mm. Timber joists and wall plates must be in good condition. If it is difficult to provide adequate ventilation or the floor timbers are in poor condition, the best option may be to install an insulated solid floor.

The standard approach to insulating a timber ground floor is to place insulation between the joists supported on a breather membrane. If the under-floor space is sufficiently deep, it will be less disruptive to insulate the floor from below, as this avoids having to lift all the floorboards. Hatches can be cut in the existing floor to access the floor void. If the under-floor space is deep enough, an additional layer of insulation may be fitted below the floor joists, as long as

this does not reduce the space under the floor to less than 150mm, or block ventilation grilles. The extra insulation will reduce thermal bridging, which results from the timber joists having a higher thermal conductivity than the insulation between them.

In many houses the under-floor space is not sufficiently deep to insulate from below, so installing insulation will involve lifting and relaying or replacing the floorboards. When the floorboards have been lifted, a breather membrane should be laid across the joist, creating cradles to hold the insulation. It is advantageous to use a semi-rigid insulation material, which can fit snugly between the joists. To avoid the risk of condensation, it is best to choose a natural material such as wood fibre, which is hygroscopic. This will reduce the risk of condensation by absorbing excess moisture from the air and releasing it when the humidity decreases. Any water pipes must be adequately insulated. A geo-textile membrane should be installed to suppress water vapour coming from damp ground into the void below the floor. Careful consideration needs to be given to the detailing at the junctions of the floor with the walls to reduce draughts and thermal bridging. If the floorboards have been lifted it is advisable to install a vapour control membrane above the insulation and below the floorboards. If the existing floorboards have not been lifted and there are gaps between boards, small lengths of timber or proprietary draught-proofing can be wedged between boards.

### Underfloor heating being installed (the manifold fixed to wall distributes the heat)

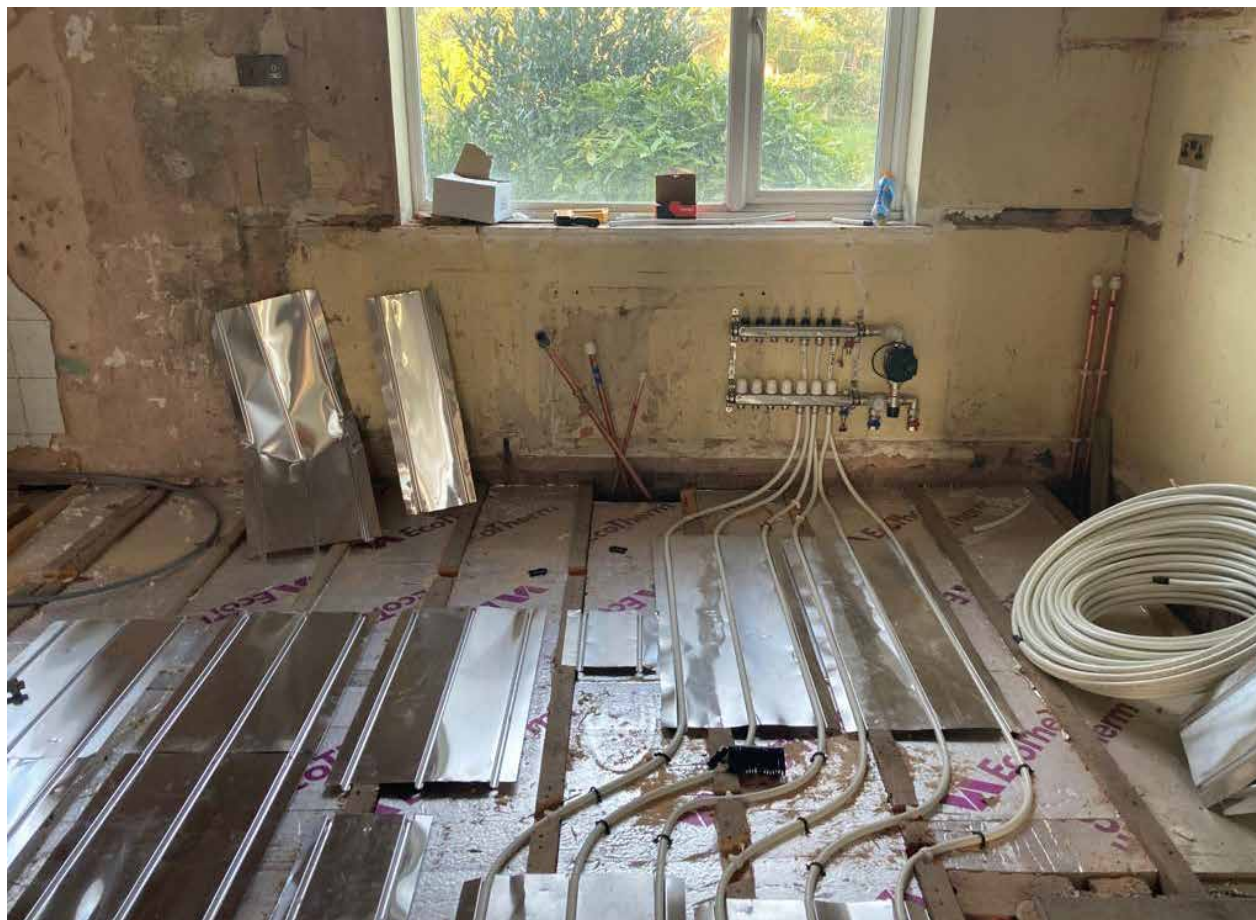

Source: Diana Collins

When installing floor insulation, you may wish to consider installing underfloor heating, which operates effectively at the lower water temperature provided by heat pumps and which can provide greater comfort than traditional radiators. If you opt for underfloor heating, you will need to replace existing floorboards with engineered wood flooring.

### Suspended timber floor (before)

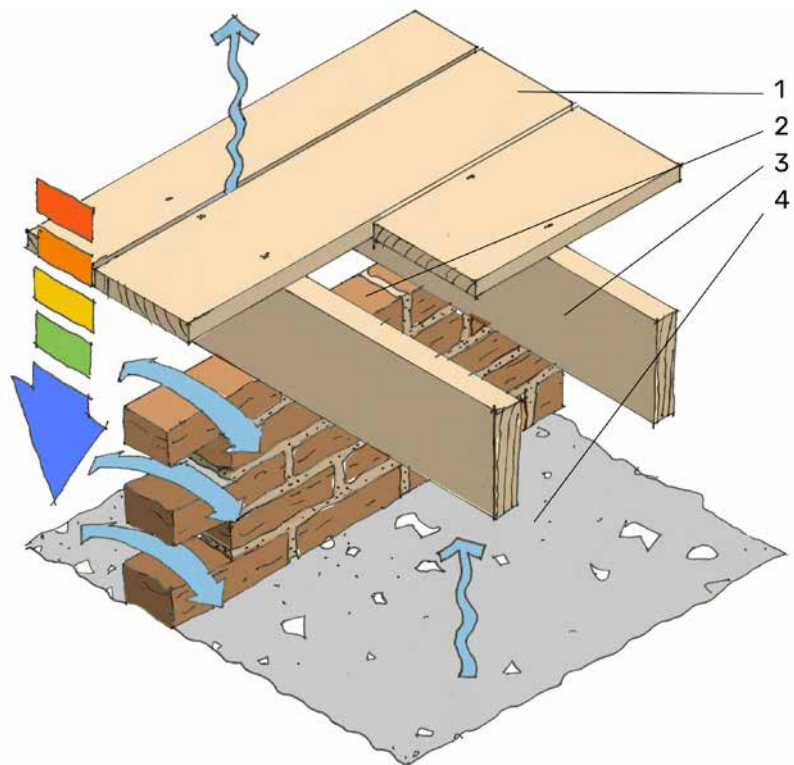

#### Key

- 1 existing floorboards with water vapour and air leakage
- 2 existing brick sleeper wall with hit and miss air vents
- 3 existing timber joists
- 4 existing ground with or without an oversite screed

### Suspended timber floor with insulation and underfloor heating

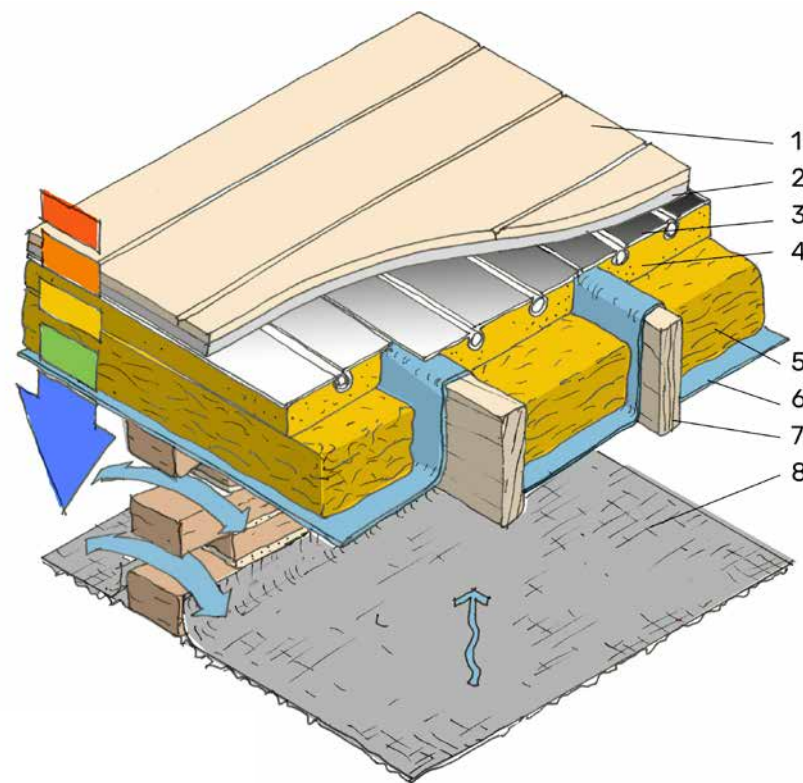

#### Key

- 1 new floor finish
- 2 cement fibre board deck
- 3 proprietary aluminium heat reflector with heating pipes
- 4 high-performance insulation integrated with reflector plate
- 5 friction-fit mineral or bio-based insulation batt
- 6 breather membrane cradles
- 7 existing joists
- 8 geo-textile membrane for weed and vapour suppression

# Insulating solid ground floors

Most ground bearing floors were constructed with a sand and cement screed above a concrete slab. Most screeds are relatively weak and friable so come up easily. One can use the depth of the screed (say 50mm to 65mm) to install a specialised insulation and floor heating system which works within this thickness.

If you want to avoid the disruption of hacking up the screed, insulating an existing solid floor will raise the height of the floor, which will impact on door openings and skirtings, and reduce headroom. As this results in a pressure to keep the insulation as thin as possible, it is advisable to choose a material with the lowest U-value possible. Even a thin layer of insulation will have a significant impact on comfort. Prior to installation any existing floor finishes should be removed. Careful consideration should be given to the detailing of the wall/floor junction to avoid a thermal bridge. Doors will also need to be cut down to swing freely above insulation.

If installing a new solid floor, particularly in an historic building, you should consider using limecrete instead of concrete, because it is breathable, which will avoid potential problems of dampness in walls without damp proof courses.

Solid ground floor (before)

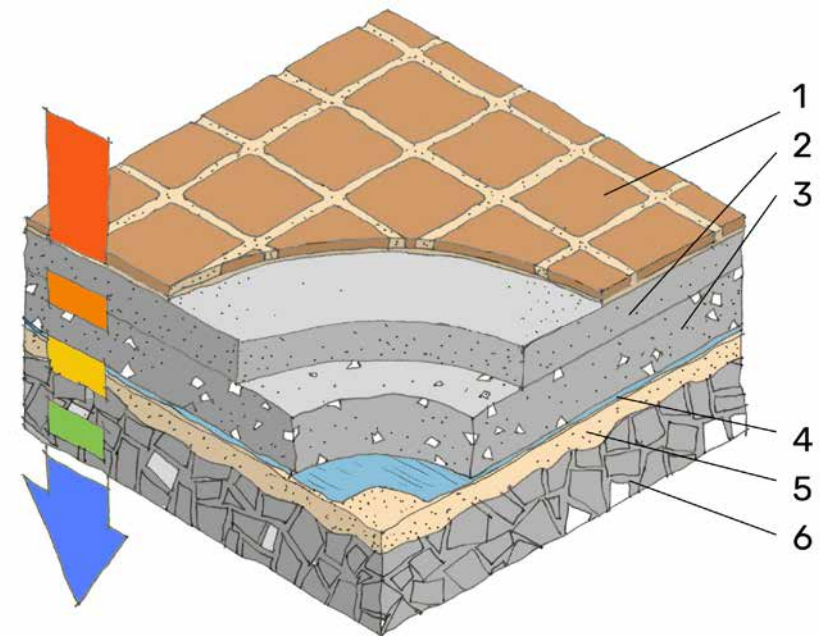

Key

- 1 existing floor finish
- 2 existing sand and cement screed
- 3 existing concrete slab
- 4 existing damp proof membrane
- 5 existing sand blinding
- 6 existing consolidated ground

### Solid ground floor with insulation and underfloor heating

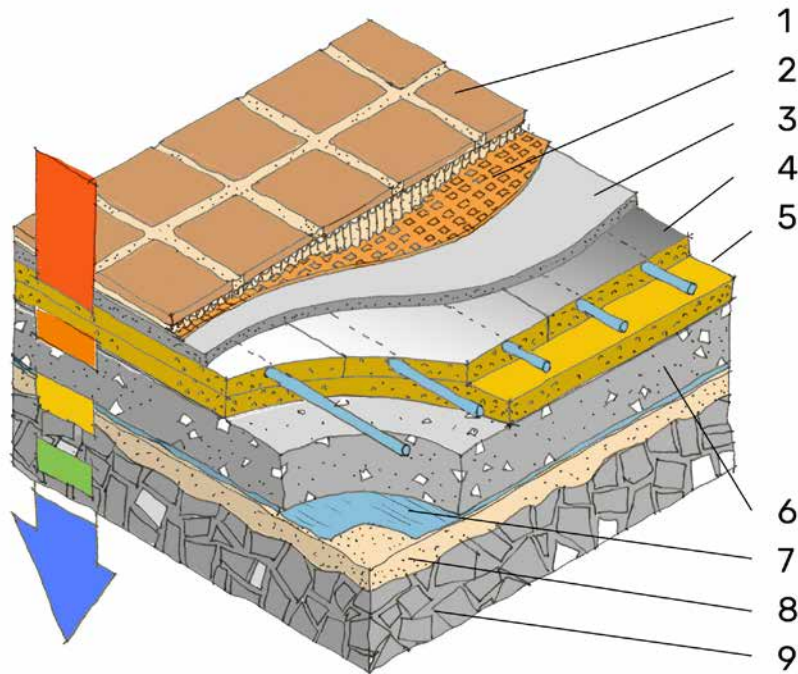

- Key
- 1 new floor finish
  - 2 tiling decoupling membrane
  - 3 cement fibre board
  - 4 proprietary underfloor heating with foil-faced high performance insulation and wet heating pipes
  - 5 high performance floor insulation
  - 6 existing concrete slab
  - 7 existing damp proof membrane
  - 8 existing sand blinding
  - 9 existing consolidated ground

### Limecrete floor with insulation

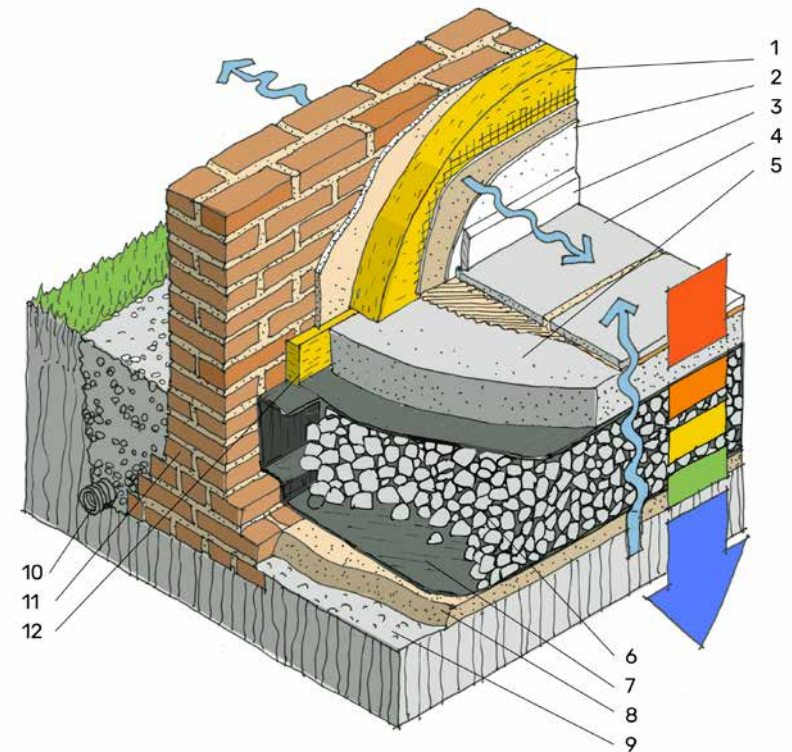

- Key
- 1 new internal wall insulation
  - 2 new lime plaster with mineral paint finish
  - 3 new skirting
  - 4 new vapour open floor finish (e.g. quarry tile)
  - 5 limecrete screed
  - 6 foamed glass insulating aggregate
  - 7 geotextile membrane wrapping the foamed glass aggregate
  - 8 sand blinding
  - 9 consolidated ground
  - 10 ground drain in pea shingle to improve drainage at the base of wall
  - 11 existing solid masonry wall (no damp proof course)
  - 12 resilient perimeter insulation (e.g. cork strip)

# Heat pumps

For well insulated homes heat pumps offer an economical low carbon heat source. It is the UK Government's policy to phase out gas boilers, so if your existing gas boiler is needing replacement, you should now consider installing a heat pump. In England there are currently grants of £7500 towards the cost of the installation of air source heat pumps and VAT is charged at 0% on their installation.

Heat pumps take heat from outside air, ground or water, and boost its temperature, and then transfer the heat to warm your home. Like a refrigerator, a heat pump uses an electrically driven compressor to circulate a refrigerant gas in a closed circuit. Air source heat pumps are generally most appropriate for domestic installations. Even when the air outside is 5°C, a heat pump can raise the water temperature around 40°C via a heat exchanger. Heat pumps can produce about three times more heat energy than the electrical energy used.

The operational equipment of an air source heat pump is housed in a large box, which needs to be located outside the building. Heat pumps should be sited where there is a good flow of air and easy access for maintenance. Their installation does not require planning permission provided certain conditions are met including size and distance from the boundary. Planning permission will be required if they are located within the curtilage of a listed building or are visible from a public highway in a Conservation Area. Further information on planning requirements is available from the [Planning Portal](#).



Source: Nicki Myers Ovesco

There have been some past concerns that heat pumps are noisy, but the technology has improved and this is now less of an issue. The operation of the fan in heat pumps produces a low hum, usually less than 40 decibels. In colder weather the pumps have to work harder and the noise level may increase to 60 decibels. The noise produced by the average gas boiler is of a similar order.

Like most of our gas fired central heating systems, heat pumps generally use water to distribute the heat produced around the home. The flow temperature for the water in gas fired systems is usually

between 60°C and 70°C. Heat pumps provide a lower flow temperature of between 35°C and 55°C, and work more efficiently at lower flow temperatures. Rather than providing heat in bursts at set times of day like traditional central heating systems, heat pumps work better emitting heat over longer periods throughout the day. Because the flow temperature is lower, it may be necessary to increase the size of your radiators. Underfloor heating operates effectively at lower flow temperatures, so when installing a heat pump, you may wish to consider installing underfloor heating.

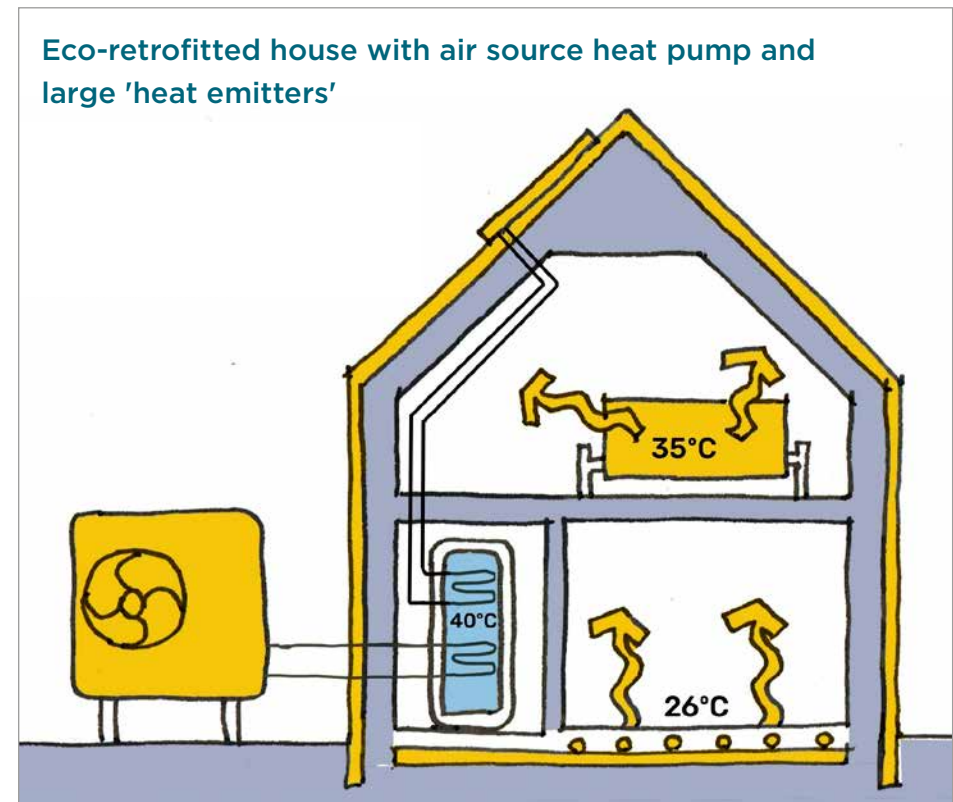
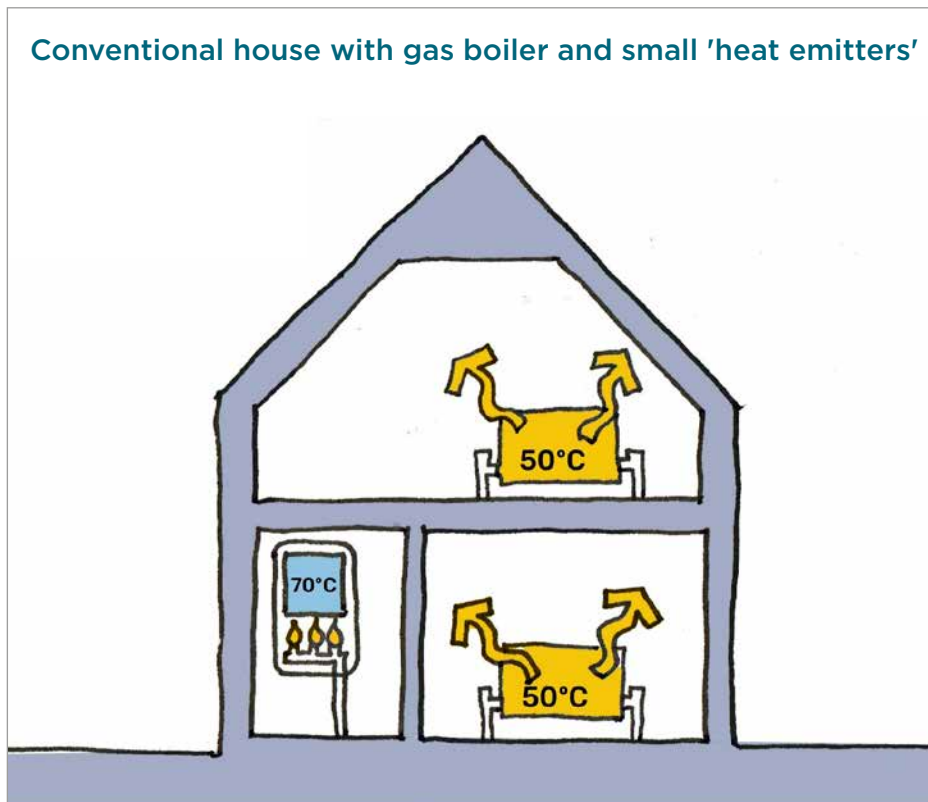

Whilst most heat pumps in the UK use water to distribute heat within the home, in other countries air is often used to distribute the heat. Air-to-air heat pumps transfer heat by fans which blow air over coils as in air conditioning units. They can be used to provide cool air as well as warm air. Because they are smaller, they may be a good option for a flat. However, in the UK at present, grants are not available for their installation.

Heat pumps do not heat water on demand like combi boilers, so hot water cylinders are needed to store hot water. For use with heat pumps hot water cylinders need to have a large heating coil, so that, at the lower flow temperature of the heat distribution circuit, there is a sufficiently large surface area for heat transfer. The system will have a summer mode, which means that only hot water will be heated, when space heating is not needed.

### How an air source heat pump works

- Key
- 1 outside air blown over heat exchanger
  - 2 impeller (fan)
  - 3 antifreeze absorbs heat energy from outside air
  - 4 refrigerant evaporates at low temperatures
  - 5 condenser raises temperature by compressing the vapour
  - 6 another heat exchanger takes heat into the building
  - 7 heat utilised for space and/or domestic hot water
  - 8 refrigerant cools back into liquid
  - 9 expansion valve removes pressure and cools liquid

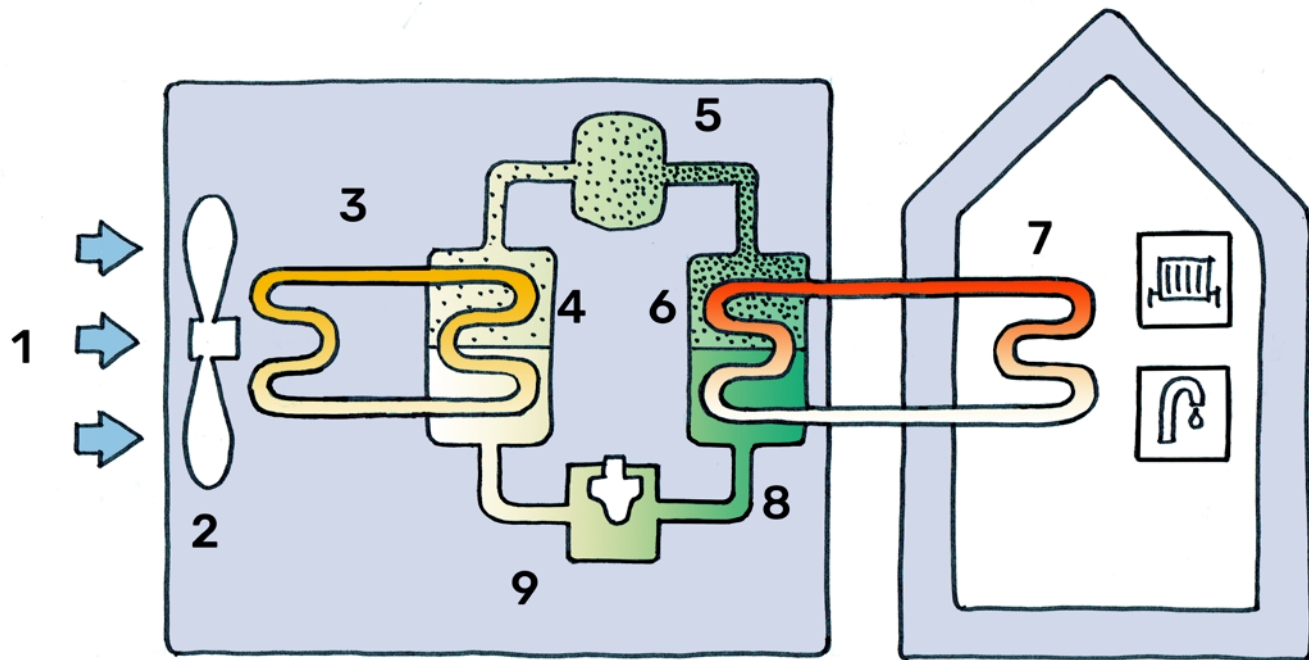

# Micro-generation

## Solar panels

Solar photovoltaic panels, often called solar PV, can be a cost effective source of renewable energy. Many homes already have solar PV panels which produce electricity for use in the home and send the surplus to the grid. Some use the surplus to power batteries which can provide power to homes in the evenings and during the night, when power is not being generated.

Solar PV panels are sensitive to orientation and the angle at which they are installed. In the UK panels facing directly south on a slope of between 30° and 40° produce the most energy. The output from panels facing southeast or southwest is 10% less and those facing west or east 20% less. Any shading of panels from trees or buildings can significantly reduce output.

Solar panels on south and west facing roof slopes



Solar PV panels turn the energy from sunlight into electricity using solar cells made from thin layers of a semiconductor material between layers of glass. The electricity produced is direct current (DC), which passes through an inverter to create alternating current (AC), which can be used in your home.

Solar PV systems are rated in kilowatts peak (kWp). This is the maximum output in optimum conditions (with the sun shining down square on the panels from a clear sky), so most of the time output will be lower. The kilowatts peak will depend on the size, type and number of panels. The output of panels on a domestic roof will usually only meet a proportion of a household's demand for electricity.

There used to be fixed rates for surplus energy sold back to the grid, but for new installations the rate paid for the electricity varies between electricity companies.

Before deciding to install solar panels, you need to make sure that your roof covering is in good condition and the roof structure can take the weight of the panels. A good time to install Solar PV is when you are renewing a roof covering and have scaffolding in place. You should choose an installer registered with the [Microgeneration Certification Scheme](#). Also see the Climate Hub list of professionals [here](#). The inverter should be located so as to minimise the cable distance from the panels to the inverter plus the cable distance from the inverter to the distribution box in order to reduce transmission losses. If you want payment for exported surplus electricity, you must have a meter that will separately measure exports. In practice this will mean you have to have a smart meter fitted.

The connection of a PV system to the grid is controlled by the local distribution network operator (DNO). In this area it is UK Power Networks and they have recently raised the size of the PV system that they will automatically approve to 5 kWp. Above this level you will need to apply for connection, and they may require the upgrade of your electrical supply. This can be expensive. Your installer will normally arrange connection approval. You may also need to upgrade the capacity of the electricity supply to your house if you want to have an adequate electric vehicle charger or a large heat pump fitted, now or in the future.

Planning permission is separate from connection approval. Solar PV panels will not require planning permission provided that a number of requirements, such as the distance which they project above roofs, are met and that your building is not Listed or in a Conservation Area or other protected area.

More detailed information is available in Ovesco's [Complete Guide to Solar PV](#).

# Solar batteries

Batteries can store energy, which is not being used when it is generated, for later use. A battery can thus enable you to use more of the energy generated by your solar panels and reduce the amount of electricity that you use from the grid. When solar panels are not generating electricity, it is possible to switch batteries to charge from the grid at off peak rates. This will often be wind energy.

Battery technology is relatively new and fast developing. Modern batteries are made of lithium so can charge and discharge many more times and can store considerably more energy for their size than older types. Batteries are reducing in price and so the payback period is also reducing. Their storage capacity is measured in kilowatt hours. The size of a battery should be based on your energy consumption, the output of your solar panel array, and the way you use electricity.

Solar batteries can be set up so they can supply electricity during a power outage. This requires a relay to be installed which isolates the system from the grid, if a power outage occurs.

Solar batteries are best located in a place that is not too cold nor too hot, such as a garage or a utility room, and close to the electrical consumer unit if possible.

Special inverters called hybrid inverters are now available that connect directly to the solar panels, the battery, and the incoming mains so that separate inverters for the panels and the battery are not needed. There is also a unit that includes the battery and hybrid inverter in one box. These inverters still require an isolation relay if you want to power the house during a power outage. There are also “diverters” that can dump excess electrical energy into a heat store tank via its immersion heater.

Wall mounted solar battery



# Solar thermal

Solar thermal panels capture heat energy from sunlight and use it to heat water directly. The heat produced is transferred to a hot water cylinder. Due to the variable solar energy available in the UK, the system will require an additional source of heat. Solar thermal systems have a relatively high cost compared to the energy saved, so will have a long payback period. Solar thermal panels can complement a heat pump by supplying most of the hot water in summer.

There are two types of collectors. Flat plate collectors have a dark absorber plate and a cover of glass or plastic over pipework containing a heat transfer fluid. Evacuated tube collectors are made of sets of two concentric tubes with a vacuum between them. Flat plate collectors are cheaper but less efficient than evacuated tube collectors especially at the ends of the heating season when cold air lowers the heat collected from the sun's rays. Vacuum tube systems are almost unaffected by air temperature and depend only on the brightness of the sunlight.

Solar thermal systems do require a hot water tank and will not work with systems that use instant heaters that only heat the water when the tap has been turned on. Even if there is a hot water storage tank, this will probably need replacing with one that has two separate coils in it, one for the solar thermal system and one for the normal heating system.

Solar thermal panel



# Sustainable drainage

As a result of climate change, we are experiencing wetter winters and more intense rainfall, which leads to a greater likelihood of flooding. Sustainable urban drainage aims to reduce this pressure on our drainage and sewer systems. There are a number of ways in which we can reduce the volume of water which runs into the drainage system and help to reduce the risk of flooding.

Wherever possible rainwater downpipes, which drain water from roofs and paved areas, should drain into soakaways, which allow water to gradually seep into the ground. Soakaways are concrete or plastic cages filled with rubble or gravel in pits in the ground.

## Rain garden planter

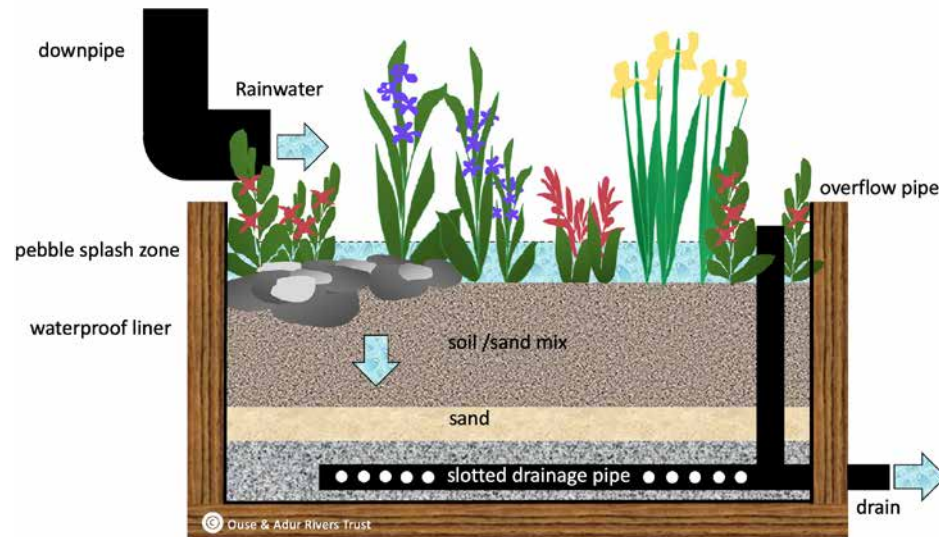

Rain garden planters can capture rainwater from downpipes, filter out pollutants and slow down its dispersal. Rainwater from a downpipe discharges directly into the planter and filters into the soil and gravel below, slowing down the rate at which water flows into the sewage system. Groundwork provides [guidance](#) on how to build rainwater planters and what to plant in them. The Ouse and Adur River Trust obtained funding from Lewes District Council to provide a number of rainwater planters on the Nevill Estate.



Source: Ouse & Adur Rivers Trust

Whilst the primary purpose of rainwater butts is to save water for use in our gardens and thus reduce our water bills, they can also make a contribution to slowing down the flow of water into our drains. They are set up to divert water from rainwater downpipes until they are full. To increase the capacity of water storage, a number of water butts can be linked.

### Rainwater butt



### Bin store with green roof



Source: Ouse & Adur Rivers Trust

As the rainwater run-off from front garden paved areas and driveways can contribute to problems of flooding, permeable paving should be used wherever possible. If impermeable materials are used and rainwater run-off is not directed to drain into adjacent ground, planning permission is now required for paving of front garden areas of more than 5 square metres. Options for permeable paving are gravel, reinforced gravel or grass, and hard permeable surfaces. Whilst gravel is a relatively cheap option, it tends to scatter and is not suitable for steeply sloping drives.

### Gravel between concrete beams helps reduce the problem of gravel scattering



Green roofs can also slow down the flow of water into sewers. The Royal Horticultural Society provides [guidance](#) on how to build them and what to plant in them.

# Planning

## Planning permission

Planning permission is needed for major changes to buildings, but not for internal works except for Listed Buildings. Some retrofit measures are classified as 'permitted development' and do not need planning permission. Solar panels are now classified as permitted development provided requirements about the distance which they project above roofs are met and your building is not listed or in a Conservation Area. Heat pumps are also now classified as permitted development provided certain conditions are met. Whilst external insulation is classified as permitted development, in practice it usually involves a change of finish, for example from brick to render, which requires planning permission.

The South Downs National Park is the planning authority for the part of Lewes District within the park's boundaries. It is responsible for planning policy, but for most simple domestic applications Lewes District acts as the Council's agents. For areas within Lewes District outside the South Downs National Park, Lewes District Council is the planning authority.

[The Planning Portal](#) is a national service which provides detailed on line advice on whether planning permission is required. It also provides information on the fees which will be charged for planning applications, which can be submitted via the Planning Portal. It is still possible to submit applications on paper using forms downloadable from the Planning Portal, but this is discouraged. After an application is submitted, it is checked to ensure that all the correct information has

been included and the correct fee paid before being validated. Planning applications should then usually be decided within eight weeks.

## Conservation Areas and listed buildings

Local authorities may designate Conservation Areas in any area of special historic or architectural interest. In most Conservation Areas, an Article 4 Direction suspends permitted development rights and provides an additional layer of protection to preserve the character of the area. Conservation Area Appraisal and Management Plans provide more detailed guidance. A list of [Conservation Areas in Lewes District Council](#) is available on its website. Individual buildings that are considered to be of special architectural or historic interest can be listed, which gives them greater legal protection. Listed Buildings may be located in Conservation Areas, but can also be in non-designated areas. Many buildings in Conservation Areas are not listed and may not be of special historic or architectural interest.

In the context of the climate crisis, the recently adopted [Lewes Conservation Area Appraisal and Management Plan](#) recognises the urgency of retrofitting buildings to make them more energy efficient. It advocates an approach to retrofit based on a 'whole building approach' and emphasises the need for breathable construction to protect the existing fabric of historic buildings. This corresponds with the approach which is advocated in this guide. External works to buildings in the Conservation Area will generally require planning permission, but internal works to non-listed buildings will not. Alterations to windows

---

will require planning permission. The installation of solar panels is encouraged on rear sloping roofs not visible from the public realm, but will require planning permission. Consents will be required for the installation of heat pumps to buildings in the Conservation Area. The plan makes reference to best practice documents produced by Historic England and the Sustainable Traditional Buildings Alliance, but does not provide advice on what energy saving improvements to the external fabric of buildings will be acceptable.

The Architects Climate Action Network have produced a [Climate Emergency Conservation Area Toolkit](#), which offers detailed advice on how buildings within a Conservation Area can be improved in a way which respects the historic context.

Listed Buildings are designated as having historic or architectural interest in their own right. In addition to planning permission, works to the interior or exterior of a Listed Building will require Listed Buildings Consent. This will apply to any repairs or alterations which affect the character of the building. It is a criminal offence to carry out works to a Listed Building without consent.

In Lewes District the Conservation Officers provide [free bookable advice sessions](#).

# Building Control

The Building Regulations are national minimum standards for design, construction and alterations to buildings. Approved documents provide detailed information on compliance. For most retrofit works, your builder, architect or surveyor will need to apply to Lewes District Building Control, which provides guidance and advice, detailed plan checking and site inspections to ensure compliance with the Building Regulations. There are two types of application, a full plans application or a building notice application. Both types of application require the payment of a fee. A full plans application requires a full set of drawings and a specification of the proposed works. Approval of a full plans application can take up to eight weeks, but it is usually much quicker. A building notice application is suitable for simple works and work can start 48 hours after submitting the notice. However, you do not have the reassurance of building to approved plans as with a full plans application. Following site inspections, the Building Control Surveyor may require works built incorrectly to be amended, which will incur further costs.

For some types of works, installers may be registered to carry out and certify works as in compliance with the Building Regulations. For example, FENSA (the Fenestration Self-Assessment Scheme) approved window and door installers can certify the compliance of works which they carry out.

# Grants

This section summarises the various ways you may be able to get a grant to cover the costs of retrofit work on your home. Some grants are targeted at people on benefits or on low incomes, including tenants.

## The Energy Company Obligation (ECO) scheme

If you or someone you live with is receiving benefits, then you should talk to your energy supplier to see if they can give you any advice. If you are unsure about this, talk to Ovesco first. They should be able to tell you what help is available through the [Energy Company Obligation \(ECO\)](#). Under the [ECO](#) scheme, energy suppliers must install energy efficiency measures in the homes of the people who need them most, including tenants. This includes a range of insulation and heating works. Lewes District Council has a [statement](#) about this. [The UK government's website](#) has information and guidance on financial support and saving energy at home. If you need help with this online service, you can call 0800 098 7950. More information [here](#) and [here](#)

## Local grants

[Warm East Sussex](#) Apply online or text **WARM** to **80011** or call **0800 464 7307**. Free visit for assessment, advice and grants if eligible. You need to be on a low income and be living with a long term condition or disability, or be receiving certain benefits and own or rent privately. Income thresholds vary with size of household. Eligible households can receive an expert holistic home energy efficiency assessment. Council homes are dealt with separately.

## Other national grants

Boiler Upgrade Scheme (BUS): the [grant for heat pumps](#) went up from £5,000 to £7,500 in October 2023. [Octopus Energy](#) offer to install a heat pump for £500 using the government grant. You may need to add additional radiators or increase their size, which will not be covered by the grant. Other electricity companies are starting to offer such deals. [The Great British Insulation Scheme](#) potentially offers free or cheaper insulation for homes with an EPC of D to G, and a council tax band of A to D. It involves energy companies commissioning the work. It has been slow to achieve take-up because installers are unwilling to expand their operations in case the scheme is not maintained. Campaigners are hoping the new government will change this. It is simple to check if you qualify online at the government website.

Unless you qualify by reason of low income, there is very little grant help available, apart from the heat pump grant and possibly the insulation scheme

Before doing any major work, it is a good idea to get a whole house energy assessment done - consult the list of building professionals and tradespeople on the [Lewes Climate Hub website](#) for local retrofit assessors. Some loan providers offer home energy assessments as part of the deal.

# Loans

If you can consider a loan, there are some banks and building societies that have offers. The [Green Finance Institute](#) has a list of providers.

[Nationwide](#) offers a 0% loan for homeowners who have had a mortgage with them for 6 months or more, all of which must be for home energy-saving work such as a boiler upgrade, solar panels, air source heat pumps, cavity wall insulation, double glazing or replacement windows, electric car charging point, and loft insulation. The 0% can apply for two or five years, after which normal current rates are paid for the rest of the term, so it is only interest-free at first.

Ecology Building Society do renovation [mortgages](#) and Skipton Building Society offer [Green Additional Borrowing](#) and [help with energy assessment](#).

Proceed carefully and check whether the schemes above are still current. You may also want to see what loans your own bank or building society are offering.

Some councils give low cost loans, but although Lewes District Council in its Climate and Nature strategy update (July 2024) mentions setting aside money to do this, loans are not yet available. They aim to enable a [retrofit loan scheme](#) and invest at least £750,000, in 2025.

# Low cost options

If you cannot afford to undertake major works, free and low cost options are available on [Lewes Climate Hub website](#). Free and low cost options were described by Nicki Myers in a talk in 2023 – view video [here](#).

# VAT and energy-saving materials and heating equipment

It is not particularly well known but the Government has made some forms of eco-retrofit eligible for a lower rate of VAT. The rules are regularly changed and the restrictions for eligibility are onerous.

The key to planning a project to exploit zero-rate VAT is to avoid including works which might be seen as refurbishment of the existing home and definitely not involving any form of extension and alteration work. You cannot, as it were, carve out the zero-rated VAT elements from the rest of the project in the eyes of the VAT officer. If your project also requires anything not strictly considered energy efficiency work, then this may entail having to have multiple phases of work to separate them into discrete sequences and contracts.

Another essential watchpoint is to check the Government's website for the latest iteration of the reduced VAT criteria both in terms of what works are eligible and what methodology is used to assess a reduced rate claim. The current Government advice note is:

[Energy-saving materials and heating equipment \(VAT Notice 708/6\)](#)

You also need to ensure the builder/installer is comfortable in taking on the project whereby they will be expected to make a reduced rate of VAT claim. It is them who inevitably have to carry the can if the VAT officer does not agree with the submission. However, if the work is purely pertaining to the energy efficiency upgrade of the property or perhaps it involves, for instance, a heat pump installation with associated improvements to the heat distribution network, then it should be fairly straightforward.

The zero rate VAT items also pertain to ancillary works needed to carry out the energy saving installations. For instance, if you need to remove a kitchen to install internal wall insulation, you can include the kitchen removal and reinstatement as part of the works. Taking the opportunity to replace the kitchen with a new one may give rise to a challenge by the VAT officer so caution is needed. It is helpful to ask the question, "would I be doing this work if I was not installing energy saving materials and/or heating equipment?" If the answer is 'no', that ancillary work probably is acceptable on a reduced VAT claim.

A key element to understand in the assessment methodology is around the definitions of a single supply and multiple supply. In short a single supply is two or more elements which are chargeable at one rate (say 0%) and a multiple supply is two or more elements chargeable at different rates of VAT.

It is frustrating that energy saving work involving the upgrading of windows or adding secondary glazing is not included in the Government's current list of energy saving measures.

## Advice with paying bills

If you are in urgent need of help with energy bills, contact Ovesco, which is a not-for-profit co-operative. They provide drop-in advice in the Energy Room at Lewes House, and in other venues. One-to-one advice is also available. They sometimes visit people's homes if it seems to be necessary, and can refer to other agencies such as Warm East Sussex. One neighbour's experience of these services was overwhelmingly positive. Ovesco gave advice on what to do about a cold conservatory without causing huge disruption. The Warm East Sussex person even climbed into the loft to take photos and reassure her that there were no holes. These services are trustworthy and impartial.

Contact via Ovesco website or [energyadvice@ovesco.co.uk](mailto:energyadvice@ovesco.co.uk) or ring 0800 458 9045

# Useful resources

The guides below can be downloaded from the internet. Some of the advice relates to specific geographic areas but most of the advice is generally applicable.

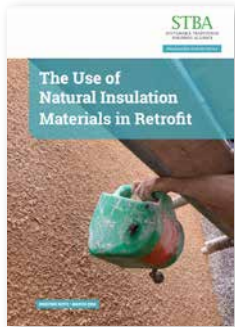

[The Use of Natural Insulation Materials in Retrofit](#) provides guidance on how natural materials can reduce risk in retrofit, minimise the environmental impact of construction and deliver healthier buildings.

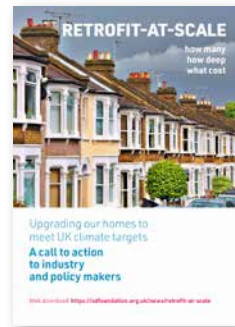

[Retrofit at Scale](#) is a 'call to action' to policy makers and the industry. It proposes a 'basic retrofit' which aims to reduce households' demand for energy for heating by 50%.



[Sustainable Renovation](#) includes comprehensive advice on how to improve the energy efficiency of the fabric of buildings, with detailed illustrations.

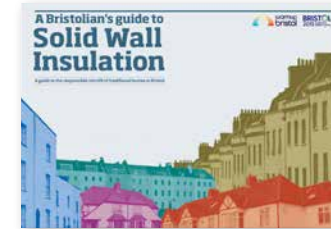

[A Bristolian's Guide to the Solid Wall Insulation](#) includes good practice building details.

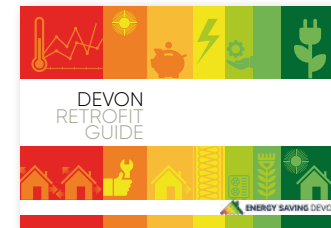

[The Devon Retrofit Guide](#), a fully comprehensive approach.



[The Trust Mark Guide to Retrofit](#) explains the benefits of the Trust Mark scheme and how to find tradespeople who are Trust Mark registered.

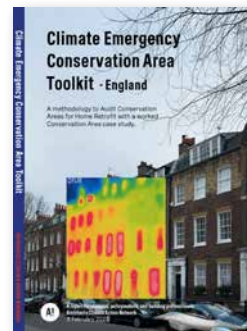

[The Climate Emergency Conservation Area Toolkit](#) provides a comprehensive approach to retrofitting buildings in a conservation area.



Historic England's [Adapting Historic Buildings for Energy and Carbon Efficiency](#) provides advice on how to approach retrofitting historic buildings, the permissions required and common interventions.



[The Leti Climate Emergency Retrofit Guide](#) explains retrofit principles and includes case studies of a range of house types.